

FLENDER COUPLINGS
CATALOG **FLE 10.2**
EDITION 2020 EN

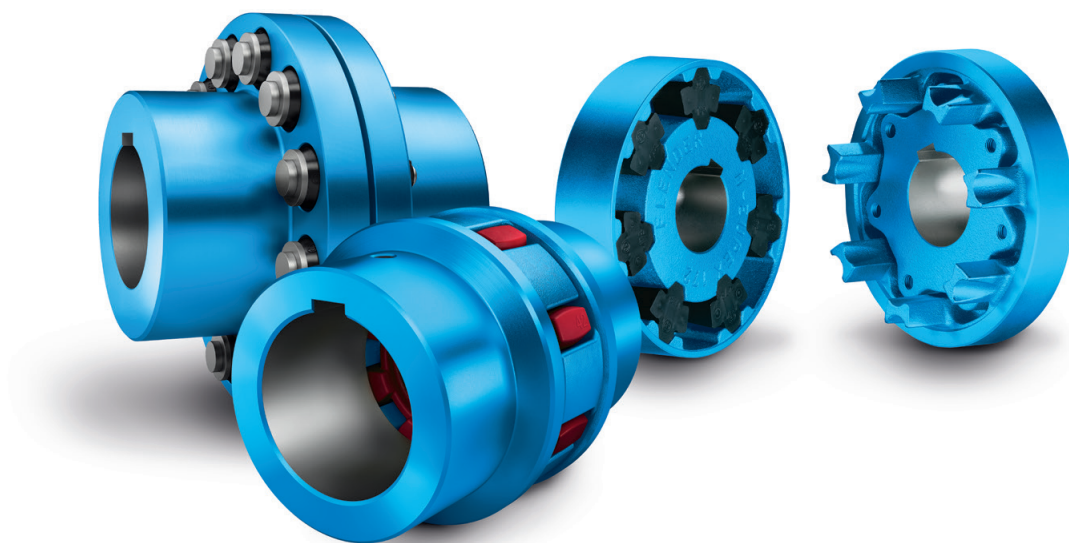

FLEXIBLE COUPLINGS
N-EUPEX, RUPEX AND N-BIPEX

FLE 10 CATALOG GROUP



Product catalog FLE 10.1
Torsionally Rigid Couplings



Product catalog FLE 10.3
Highly Flexible Couplings



Product catalog FLE 10.2
Flexible Couplings



Product catalog FLE 10.4
Fluid Couplings

For further coupling catalogs, see page A/6

FLEXIBLE COUPLINGS



Catalog FLE 10.2 Edition 2020 EN

Introduction

Torsionally Rigid Gear Couplings

ZAPEX ZW

ZAPEX ZN

Torsionally Rigid All-Steel Couplings

N-ARPEX, ARPEX

Flexible Couplings

N-EUPEX

RUPEX

N-BIPEX

Highly Flexible Couplings

ELPEX-B

ELPEX-S

ELPEX

Fluid Couplings

FLUDEX

Appendix

E

4

5

6

7

8

9

10

11

12

13

A

INTRODUCTION

E

The mechanical drive train comprises individual units such as motor, gear unit and driven machine. The coupling connects these component assemblies.

As well as the transmission of rotary motion and torque, other requirements may be made of the coupling.

- Compensation for shaft misalignment with low restorative forces
- Control of characteristic angular vibration frequency and damping
- Interruption or limitation of torque
- Noise insulation, electrical insulation

Couplings are frequently chosen after the machines to be connected have already been selected. Thanks to a large number of different coupling assembly options, specified marginal conditions for clearance and connection geometry can be met from the standard range. The coupling also performs secondary functions, e.g. providing a brake disk or brake drum for operating or blocking brakes, devices to record speed or the attachment of sprockets or pulleys.

Couplings are divided into two main groups, couplings and clutches.

Clutches interrupt or limited the transmissible torque. The engaging and disengaging forces on externally operated clutches are introduced via a mechanically, electrically, hydraulically or pneumatically operating mechanism. Overload, centrifugal or freewheel clutches draw their engaging energy from the transmitted output.

Rigid couplings, designed as clamp, flanged or mechanism couplings, connect machines which must not undergo any shaft misalignment. Hydrodynamic couplings, often also called fluid or Föttinger couplings, are used as starting couplings in drives with high mass moments of inertia of the driven machine. In drive technology very often flexible, positive couplings, which may be designed to be torsionally rigid, torsionally flexible or highly flexible, are used.

Torsionally rigid couplings are designed to be rigid in a peripheral direction and flexible in radial and axial directions. The angle of rotation and torque are conducted through the coupling without a phase shift.

Torsionally flexible couplings have resilient elements usually manufactured from elastomer materials. Using an elastomer material with a suitable ShoreA hardness provides the most advantageous torsional stiffness and damping for the application. Shaft misalignment causes the resilient elements to deform.

Highly flexible couplings have large-volume (elastomer) resilient elements of low stiffness. The angle of rotation and torque are conducted through the coupling with a considerable phase shift.

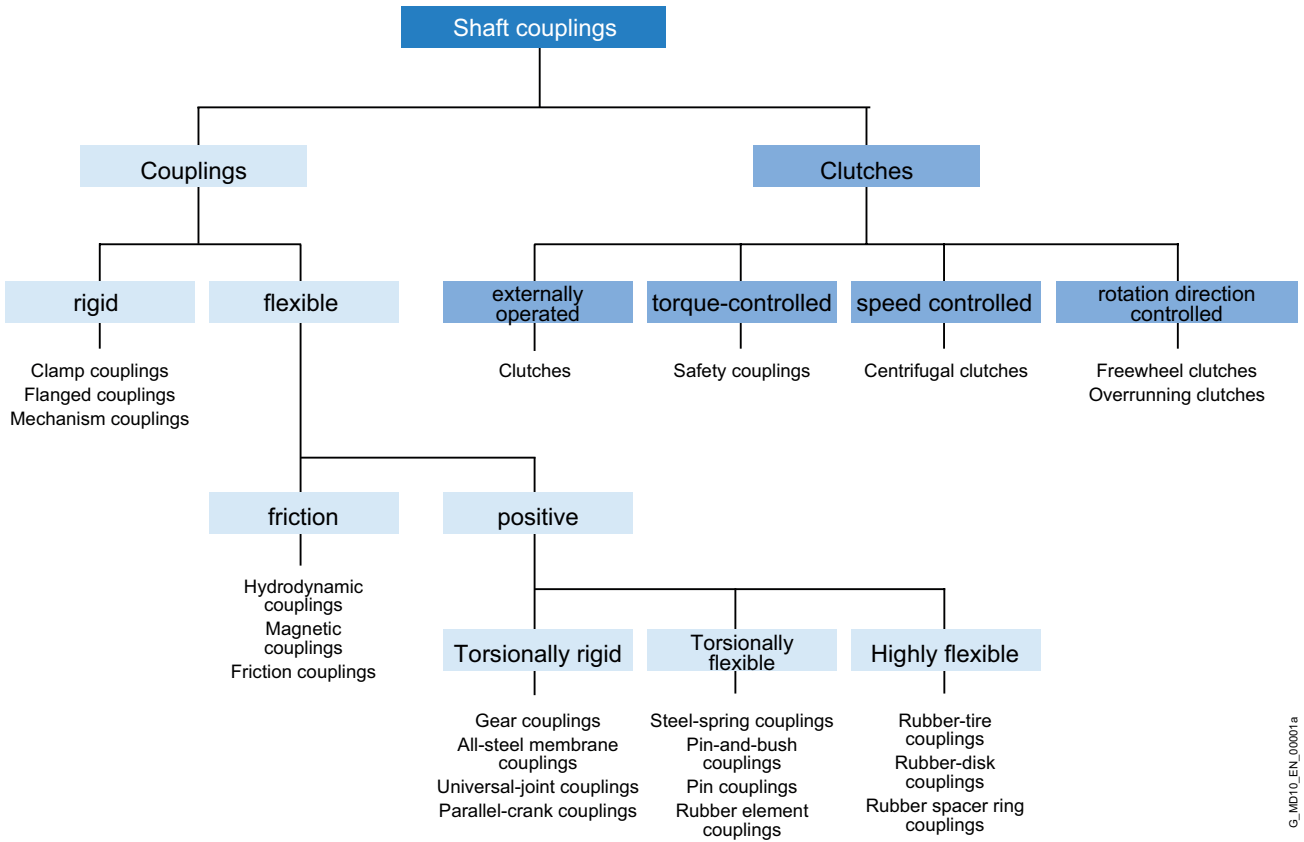

G_ID10_EN_00001a

OUR COUPLING GROUPS AT A GLANCE

E

N-EUPEX, RUPEX and N-BIPEX

Flexible Couplings

Flexible Flender couplings have a wide range of possible applications. A broad standard modular system as well as specially designed application-specific couplings are available.

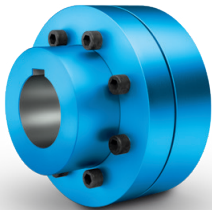

N-EUPEX
cam couplings
Rated torque:
19 Nm ... 62,000 Nm

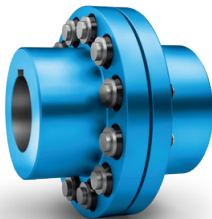

RUPEX
pin-and-bush couplings
Rated torque:
200 Nm ... 1,300,000 Nm



N-BIPEX
cam couplings
Rated torque:
12 Nm ... 4,650 Nm

ELPEX, ELPEX-B and ELPEX-S

Highly Flexible Couplings

ELPEX® couplings are free of circumferential back-lash. Their damping capacity and low torsional stiff-ness make them especially well-suited for coupling machines with strongly non-uniform torque characteristics or large shaft misalignment.

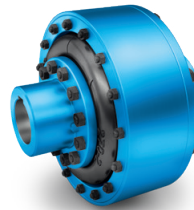

ELPEX
elastic ring couplings
Rated torque:
1,600 Nm ... 90,000 Nm



ELPEX-B
elastic tire couplings
Rated torque:
24 Nm ... 14,500 Nm



ELPEX-S
rubber disk couplings
Rated torque:
330 Nm ... 63,000 Nm

ZAPEX gear couplings and ARPEX all-steel couplings

Torsionally rigid couplings

For transmission of high torques, we offer both ARPEX all-steel couplings and ZAPEX gear couplings in a range of versions. Their purposes of application vary according to specific requirements with respect to shaft misalignment, temperature and torque.

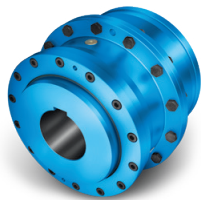

ZAPEX
gear couplings
Rated torque:
1,300 Nm ... 7,200,000 Nm

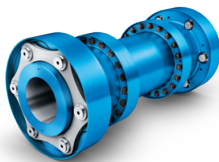

ARPEX
high Performance Couplings
Rated torque:
1,000 Nm ... 588,500 Nm



N-ARPEX and ARPEX
all-steel couplings
Rated torque:
92 Nm ... 2,000,000 Nm

BIPEX-S and SIPEX

Backlash-free couplings

The vibration-damping, electrically insulating plug-in BIPEX-S elastomer couplings and SIPEX metal bellows couplings with very high torsional stiffness deliver especially isogonal torque transmission.



BIPEX-S and SIPEX
Rated torque:
0.1 Nm ... 5,000 Nm

FLUDEX

Hydrodynamic couplings

The FLUDEX hydrodynamic fluid coupling works according to the Föttinger principle. It functions entirely free of wear.



FLUDEX
fluid Couplings
Power:
1.2 kW ... 2,500 kW

Application-specific couplings

Couplings for rail vehicles must meet high demands. Due to their high degree of standardization and wide variety, they can be used in the most diverse vehicle types.

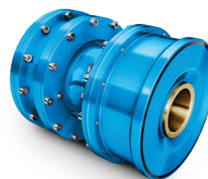

Railway coupling
Rated torque:
1,000 Nm ... 9,500 Nm

Each wind turbine coupling is designed to optimally meet the requirements of the respective wind turbine. The coupling connects the fast-running gear shaft with the generator shaft and is available for wind turbines with a capacity of up to 12 MW.

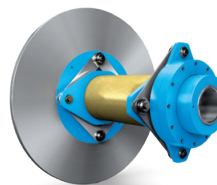

Wind turbine couplings
Rated torque:
10,000 Nm ... 60,000 Nm

TECHNICAL INFORMATION AND COUPLING SELECTION

E

Technical Information	E/8
Shaft misalignment	E/8
Balancing	E/9
Shaft-hub connections	E/11
Standards	E/12
Key to symbols	E/13
<hr/>	
Selection of the coupling series	E/14
Typical coupling solutions for different example applications	E/15
<hr/>	
Selection of the coupling size	E/16
Coupling load in continuous operation	E/16
Coupling load at maximum and overload conditions	E/17
Coupling load due to dynamic torque load	E/17
Checking the maximum speed	E/18
Checking permitted shaft misalignment	E/18
Checking bore diameter, mounting geometry and coupling design	E/18
Coupling behavior under overload conditions	E/18
Checking shaft-hub connection	E/18
Checking low temperature and chemically aggressive environment	E/18
<hr/>	
Features of the standard type	E/19
<hr/>	

TECHNICAL INFORMATION

E

Shaft misalignment

Shaft misalignment is the result of displacement during assembly and operation and, where machines constructed with two radial bearings each are rigidly coupled, will cause high loads being placed on the bearings. Elastic deformation of base frame, foundation and machine housing will lead to shaft misalignment which cannot be prevented, even by precise alignment.

Furthermore, because individual components of the drive train heat up differently during operation, heat expansion of the machine housings causes shaft misalignment. Poorly aligned drives are often the cause of seal, rolling bearing or coupling failure. Alignment should be carried out by specialist personnel in accordance with operating instructions.

Depending on the direction of the effective shaft misalignment a distinction is made between:

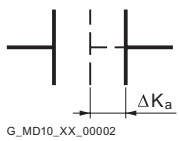

Axial misalignment

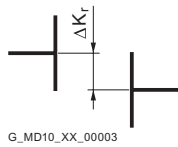

Radial misalignment



Angular misalignment

Couplings can be categorized into one of the following groups:

Single-joint couplings

Couplings with flexible elements mainly made of elastomer materials. Shaft misalignment results in deformation of the elastomer elements. The elastomer elements can absorb shaft misalignment as deformations in an axial, radial and angular direction. The degree of permissible misalignment depends on the coupling size, the speed and the type of elastomer element. Single-joint couplings do not require an adapter and are therefore short versions.

Example:

In the case of a RUPLEX RWN 198 coupling with an outer diameter of 198 mm and a speed of 1500 rpm, the permitted radial misalignment is $\Delta K_r = 0.3$ mm.

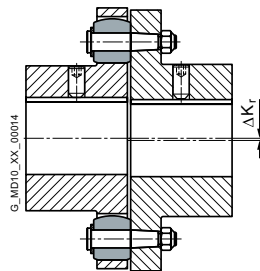

Two-joint couplings

Two-joint couplings are always designed with an adapter. The two joint levels are able to absorb axial and angular misalignment. Radial misalignment occurs via the gap between the two joint levels and the angular displacement of the joint levels. The permitted angular misalignment per joint level is frequently about 0.5°. The permitted shaft misalignment of the coupling can be adjusted via the length of the adapter. If there are more than two joint levels, it is not possible to define the position of the coupling parts relative to the axis of rotation. (The less frequently used parallel-crank couplings are an exception).

Example:

N-ARPEX ARN-6 NEN 217-6 with a shaft distance of 140 mm with a permitted radial misalignment of $\Delta K_r = 2.2$ mm (angle per joint level 1.0°).

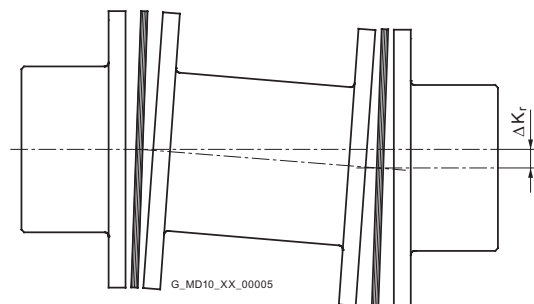

Balancing

Balance quality levels

The so-called quality level G to DIN ISO 21940 indicates a range of permitted residual imbalance from zero up to an upper limit. Applications can be grouped on the basis of similarity analysis. For many applications a coupling balance quality of G 16 is sufficient. On drives susceptible to vibration the balance quality should be G 6.3. Only in special cases is a better balance quality required.

Balancing standard in accordance with DIN ISO 21940-32

Besides the required balance quality, it is necessary to set standards which define how the mass of the parallel key is to be taken into consideration when balancing. In the past, motor rotors have frequently been balanced in accordance with the full parallel key standard. The "appropriate" balance condition of the coupling hub was described as "balancing with open keyway" or "balancing after keyseating". Today it is usual for the motor rotor, as well as the gear unit and driven machine shaft, to be balanced in accordance with the half parallel key standard.

Full parallel key standard

The parallel key is inserted in the shaft keyway, then balancing is carried out. The coupling hub must be balanced without parallel key after keyseating.

Marking of shaft and hub with "F" (for "full").

Half parallel key standard

The balancing standard normally applied today. Before balancing, a half parallel key is inserted in the shaft and another in the coupling hub. Alternatively, balancing can be carried out before cutting the keyway.

The balanced parts must be marked with an "H". This marking can be dispensed with if it is absolutely clear which parallel key standard has been applied.

No parallel key standard

Balancing of shaft and coupling hub after keyseating, but without parallel key. Not used in practice. Marking of shaft and hub with "N" (for "no").
The length of the parallel key is determined by the shaft keyway. Coupling hubs may be designed considerably shorter than the shaft.

To prevent imbalance forces caused by projecting parallel key factors when balancing in accordance with the half parallel key standard in the case of applications with high balancing quality requirements, grooved spacer rings can be fitted or stepped parallel keys used.

Flender Balancing Standard

The balancing quality level, together with the operating speed, results in the maximum permissible eccentricity of the center of gravity of the coupling or the coupling subassembly. In the Flender article number the balancing quality can be preset with the help of the order code. Additionally, also the balance quality level to DIN ISO 21940 can be preset together with the operating speed belonging to it, which then be taken as priority.

$$e_{perm} = 9550 \cdot \frac{G}{n}$$

$$e_{coupl} \leq e_{perm}$$

Permitted eccentricity of center of gravity e_{perm} in μm
 Eccentricity of center of gravity of coupling e_{coupl} in μm
 Balancing quality level G in mm/s
 Coupling speed n in rpm

Eccentricity of center of gravity of coupling e_{coupl}	Flender balancing quality	Order code
maximum 100 μm	standard balancing	without specification
maximum 40 μm	fine balancing	W02
maximum 16 μm	micro-balancing	W03
better than 16 μm	special balancing	on request

TECHNICAL INFORMATION

E

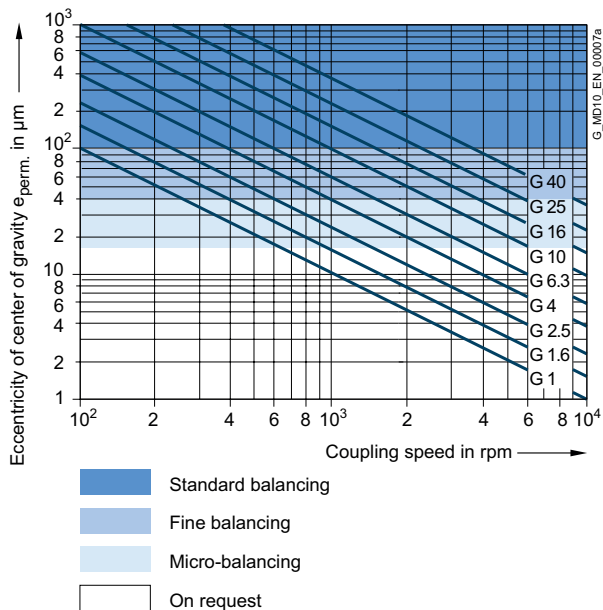

Example:
Coupling speed = 1450 rpm
required balancing quality level G 6.3

$$e_{perm} = 9550 \cdot \frac{G}{n} = 9550 \cdot \frac{6.3}{1450} \mu\text{m}$$

Thus, the required eccentricity of center of gravity is 41.5 µm. The fine balancing with a maximum eccentricity of center of gravity of 40 mm fulfills this requirement; therefore, the order code W02 has to be specified when ordering.

For many applications the following balancing quality recommendation applies:

Coupling	standard balancing $v = DA \cdot n/19100$	fine balancing
short version with $LG \leq 3 \times DA$	$v < 30 \text{ m/s}$	$v > 30 \text{ m/s}$
long version with $LG > 3 \times DA$	$v \leq 15 \text{ m/s}$	$v > 15 \text{ m/s}$

Peripheral speed	v	in mm/s
Coupling outer diameter	DA	in mm
Coupling speed	n	in rpm
Coupling length	LG	in mm

The following standards on balancing must be observed:

- couplings are balanced in subassemblies.
- hub parts without finished bore are unbalanced.
- the number of balancing levels (one- or two-level balancing) is specified by Flender.
- without special specification balancing is done in accordance with the half-parallel-key standard. Balancing in accordance with the full-parallel-key standard must be specified in the order number.
- For FLUDEX couplings special balancing standards specified in Section 13 apply.
- ARPEX couplings in standard balancing quality are unbalanced. Thanks to steel components machined all over and precisely guided adapters the balancing quality of standard balancing is nearly always adhered to.

Shaft-hub connections

The bore and the shaft-hub connection of the coupling are determined by the design of the machine shaft. In the case of IEC standard motors, the shaft diameters and parallel key connections are specified in accordance with DIN EN 50347. For diesel motors, the flywheel connections are frequently specified in accordance with SAE J620d or DIN 6288. Besides the very widely used connection of shaft and hub with parallel keys to DIN 6885 and cylindrically bored hubs, couplings with Taper clamping bushes, clamping sets, shrink-fit connections and splines to DIN 5480 are common.

The form stability of the shaft/hub connection can only be demonstrated when shaft dimensions and details of the connection are available. The coupling torques specified in the tables of power ratings of the coupling series do not apply to the shaft-hub connection unrestrictedly.

In the case of the shaft-hub connection with parallel key, the coupling hub must be axially secured, e.g. with a set screw or end washer. The parallel key must be secured against axial displacement in the machine shaft.

All Flender couplings with a finished bore and parallel keyway are designed with a set screw. Exceptions are some couplings of the FLUDEX series, in which end washers are used. During assembly, Taper clamping bushes are frictionally connected to the machine shaft.

TECHNICAL INFORMATION

E

Standards

Machines

2006/42/EG	EC Machinery Directive
2014/34/EU	ATEX Directive – Manufacturer
1999/92/EG	ATEX Directive – Operator – and ATEX Guideline to Directive 1999/92/EC
DIN EN 80079-36	Non-electrical equipment for use in potentially explosive atmospheres
DIN EN 1127	Explosive atmospheres, explosion prevention and protection
DIN EN 50347	General-purpose three-phase induction motors having standard dimensions and outputs

Couplings

DIN 740	Flexible shaft couplings Part 1 and Part 2
VDI Guideline 2240	Shaft couplings - Systematic subdivision according to their properties VDI Technical Group Engineering Design 1971
API 610	Centrifugal Pumps for Petroleum, Chemical and Gas Industry Services
API 671	Special Purpose Couplings for Petroleum, Chemical and Gas Industry Services
ISO 10441	Petroleum, petrochemical and natural gas industries – Flexible couplings for mechanical power transmission-special-purpose applications
ISO 13709	Centrifugal pumps for petroleum, petrochemical and natural gas industries

Balancing

DIN ISO 21940	Requirements for the balancing quality of rigid rotors
DIN ISO 21940-32	Mechanical vibrations; standard governing the type of parallel key during balancing of shafts and composite parts

Shaft-hub connections

DIN 6885	Driver connections without taper action – parallel keys – keyways
SAE J620d	Flywheels for industrial engines ...
DIN 6288	Reciprocating internal combustion engines Dimensions and requirements for flywheels and flexible couplings
ASME B17.1	Keys and keyseats
DIN EN 50347	General-purpose three-phase induction motors with standard dimensions and output data
BS 46-1:1958	Keys and keyways and taper pins Specification

Key to symbols

Name	Symbols	Unit	Explanation
Torsional stiffness, dynamic	C_{Tdyn}	Nm/rad	For calculating torsional vibration
Excitation frequency	f_{err}	Hz	Excitation frequency of motor or driven machine
Moment of inertia	J	kgm ²	Moment of inertia of coupling sides 1 and 2
Axial misalignment	ΔK_a	mm	Axial misalignment of the coupling halves
Radial misalignment	ΔK_r	mm	Radial misalignment of the coupling halves
Angular misalignment	ΔK_w	°	Angular misalignment of the coupling halves
Service factor	FB		Factor expressing the real coupling load as a ratio of the nominal coupling load
Frequency factor	FF		Factor expressing the frequency dependence of the fatigue torque load
Temperature factor	FT		Factor taking into account the reduction in strength of flexible rubber materials at a higher temperature
Weight	m	kg	Weight of the coupling
Rated speed	n_N	rpm	Coupling speed
Maximum coupling speed	n_{Kmax}	rpm	Maximum permissible coupling speed
Rated power	P_N	kW	Rated output on the coupling, usually the output of the driven machine
Rated torque	T_N	Nm	Rated torque as nominal load on the coupling
Fatigue torque	T_W	Nm	Amplitude of the dynamic coupling load
Maximum torque	T_{max}	Nm	More frequently occurring maximum load, e.g. during starting
Overload torque	T_{OL}	Nm	Very infrequently occurring maximum load, e.g. during short circuit or blocking conditions
Rated coupling torque	T_{KN}	Nm	Torque which can be transmitted as static torque by the coupling over the period of use.
Maximum coupling torque	T_{Kmax}	Nm	Torque which can be frequently transmitted (up to 25 times an hour) as maximum torque by the coupling.
Coupling overload torque	T_{KOL}	Nm	Torque which can very infrequently be transmitted as maximum torque by the coupling.
Fatigue coupling torque	T_{KW}	Nm	Torque amplitude which can be transmitted by the coupling as dynamic torque at a frequency of 10 Hz over the period of use.
Resonance factor	V_R		Factor specifying the torque increase at resonance
Temperature	T_a	°C	Ambient temperature of the coupling in operation
Damping coefficient	Ψ	psi	Damping parameter

SELECTION OF THE COUPLING SERIES

E

The coupling series is frequently determined by the driven machine and the design of the drive train. Common selection criteria are listed below and assigned to coupling properties, which are used to select the coupling series. Additionally, the price of the coupling and availability are important criteria for determining the coupling series to be used.

The **FLUDEX series** operates positively and transmits the torque with the aid of a flowing oil or water filling.

FLUDEX couplings are used to reduce starting and/or overload torques. During starting, the motor may, for example, run up within a very short time; because of the FLUDEX coupling, the drive train with the driven machine may accelerate after a delay and without increased torque load.

The FLUDEX coupling cannot compensate for shaft misalignment and is therefore designed in combination with a displacement coupling, a cardan shaft or a belt drive. The displacement coupling may be selected in accordance with the criteria described below.

Selection criteria	Torque range	Speed range	Torsional stiffness		Highly flexible	Operating temperature range
	Rated coupling torque T_{KN}	Peripheral speed $v_{max} = DA \cdot n_{max}/19100$	torsionally rigid	torsionally flexible		
ZAPEX	850 ... 7200000 Nm	60 m/s	■	-	-	-20 ... +80 °C
N-ARPEX	350 ... 2000000 Nm	110 m/s	■	-	-	-50 ... +280 °C
ARPEX	92 ... 2000000 Nm	100 m/s	■	-	-	-40 ... +280 °C
N-EUPEX	19 ... 62000 Nm	36 m/s	-	■	-	-50 ... +100 °C
N-EUPEX DS	19 ... 21200 Nm	36 m/s	-	■	-	-30 ... +80 °C
RUPEX	200 ... 1300000 Nm	60 m/s	-	■	-	-50 ... +100 °C
N-BIPEX	12 ... 4650 Nm	45 m/s	-	■	-	-50 ... +100 °C
ELPEX-B	24 ... 14500 Nm	35 m/s	-	-	■	-50 ... +70 °C
ELPEX-S	330 ... 63000 Nm	66 m/s	-	-	■	-40 ... +120 °C
ELPEX	1600 ... 900000 Nm	60 m/s	-	-	■	-40 ... +80 °C

Typical coupling solutions for different example applications

The specified application factors are recommendations; regulations, rules and practical experience take priority as assessment criteria.

No application factor need be taken into account with FLUDEX couplings.

In the case of highly flexible couplings of the ELPEX, ELPEX-S and ELPEX-B series, deviating application factors are stated in the product descriptions.

FLUDEX couplings are mostly mounted on the high-speed gear shaft.

Example applications	Application factor FB
Electric motor without gear unit	
Centrifugal pumps	1.0
Piston pumps	1.5
Vacuum pumps	1.5
Fans with T_N less than 75 Nm	1.5
Fans with T_N from 75 to 750 Nm	1.75
Fans with T_N larger than 750 Nm	1.75
Blowers	1.5
Frequency converters / generators	1.25
Reciprocating compressors	1.75
Screw-type compressors	1.5
Internal-combustion engine without gear unit	
Generators	1.75
Pumps	1.5
Fans	1.75
Hydraulic pumps, excavators, construction machines	1.5
Compressors / screw-type compressors	1.5
Agricultural machinery	1.75
Other	
Turbine gear units	1.5
Hydraulic motor - gear unit	1.25
Electric motor with gear unit	
Chemical industry	
Extruders	1.5
Pumps - centrifugal pumps	1.0
Pumps - piston pumps	1.75
Pumps - plunger pumps	1.5
Reciprocating compressors	1.75
Calenders	1.5
Kneaders	1.75
Cooling drums	1.25
Mixers	1.25
Stirrers	1.25
Toasters	1.25
Drying drums	1.25
Centrifuges	1.25
Crushers	1.5
Power generation and conversion	
Compressed air, reciprocating compressors	1.75

Example applications	Application factor FB
Compressed air, screw-type compressors	1.25
Air - Blowers	1.5
Air - Cooling tower fans	1.5
Air - Turbine blowers	1.5
Generators, converters	1.25
Welding generators	1.25
Metal production, iron and steel works	
Plate tilters	1.5
Ingot pushers	1.75
Slabbing mill	1.75
Coiling machines	1.5
Roller straightening machines	1.5
Roller tables	1.75
Shears	1.75
Rollers	1.75
Metal working machines	
Plate bending machines	1.5
Plate straightening machines	1.5
Hammers	1.75
Planing machines	1.75
Presses, forging presses	1.75
Shears	1.5
Grinding machines	1.25
Punches	1.5
Machine tools: Main drives	1.5
Machine tools: Auxiliary drives	1.25
Food industry	
Filling machines	1.25
Kneading machines	1.5
Mashers	1.5
Sugar cane production	1.5
Production machines	
Construction machines, hydraulic pumps	1.25
Construction machines, traversing gears	1.5
Construction machines, suction pumps	1.5
Construction machines, concrete mixers	1.5
Printing machines	1.25
Woodworking - barking drums	1.5
Woodworking - planing machines	1.5

Example applications	Application factor FB
Woodworking - reciprocating saws	1.5
Grinding machines	1.5
Textile machines - winders	1.5
Textile machines - printing machines	1.5
Textile machines - tanning vats	1.5
Textile machines - shredders	1.5
Textile machines - looms	1.5
Packaging machines	1.5
Brick molding machines	1.75
Transport and logistics	
Passenger transport - elevators	1.5
Passenger transport - escalators	1.5
Conveyor systems - bucket elevators	1.5
Conveyor systems - hauling winches	1.5
Conveyor systems - belt conveyors	1.5
Conveyor systems - endless-chain conveyors	1.5
Conveyor systems - circular conveyors	1.5
Conveyor systems - screw conveyors	1.5
Conveyor systems - inclined hoists	1.5
Crane traversing gear	1.5
Hoisting gear	1.5
Crane lifting gear	2.0
Crane traveling gear	1.5
Crane slewing gear	1.5
Crane fly jib hoists	1.5
Cable railways	1.5
Drag lifts	1.5
Winches	1.5
Cellulose and paper	
Paper-making machines, all	1.5
Pulper drives	1.5
Cement industry	
Crushers	1.75
Rotary furnaces	1.5
Hammer mills	1.75
Ball mills	1.75
Pug mills	1.75
Mixers	1.5
Pipe mills	1.5
Beater mills	1.75
Separators	1.5
Roller presses	1.75

SELECTION OF THE COUPLING SIZE

E

The torque load of the coupling must be determined from the output of the driven machine and the coupling speed.

Rated coupling load $T_N = 9550 \times P_N / n_N$
 (T_N in Nm; P_N in kW; n_N in rpm)

The rated coupling load obtained in this way must be multiplied by factors and compared with the rated coupling torque. An ideal but expensive method is to measure the torque characteristic on the coupling. For this, Flender offers special adapters fitted with torque measuring devices.

The rated coupling torque T_{KN} is the torque which can be transmitted by the coupling over an appropriate period of use if the load is applied to the coupling purely statically at room temperature.

Application factors are to express the deviation of the real coupling load from the "ideal" load condition.

Coupling load in continuous operation

The operating principles of the driving and driven machines are divided into categories and the application factor FB derived from these in accordance with DIN 3990-1.

Application factor for N-EUPEX, N-EUPEX-DS, RUPEX, N-BIPEX, ELPEX-B, N-ARPEX, ARPEX, ZAPEX and FLUDEX

Application factor FB				
Torque characteristic of the driving machine	Torque characteristic of the driven machine			
	uniform	uniform with moderate shock loads	non uniform	very rough
uniform	1.0	1.25	1.5	1.75
uniform with moderate shock loads	1.25	1.5	1.75	2.0
non uniform	1.5	1.75	2.0	2.5

Examples of torque characteristic of driving machines:

- uniform: Electric motors with soft starting, steam turbines
- uniform with moderate shock loads: Electric motors without soft starting, hydraulic motors, gas and water turbines
- non uniform: Internal-combustion engines

Examples of torque characteristic in driven machines:

- uniform: Generators, centrifugal pumps for light fluids
- uniform with moderate shock loads: Centrifugal pumps for viscous fluids, elevators, machine tool drives, centrifuges, extruders, blowers, crane drives
- non uniform: Excavators, kneaders, conveyor systems, presses, mills
- very rough: Crushers, excavators, shredders, iron/smelting machinery

Temperature factor FT												
Coupling	Elastomer material	Low temperature °C	Temperature T_a on the coupling									
			under -30 °C	-30 °C up to 50 °C	up to 60 °C	up to 70 °C	up to 80 °C	up to 90 °C	up to 100 °C	up to 110 °C	up to 120 °C	
N-EUPEX	NBR	-30	-	1.0	1.0	1.0	1.0	1.0	-	-	-	-
N-EUPEX	NR	-50	1.1 ¹⁾	1.0	-	-	-	-	-	-	-	-
N-EUPEX	HNBR	-10	-	1.0	1.0	1.0	1.0	1.0	1.25	1.25	-	-
N-EUPEX DS	NBR	-30	-	1.0	1.0	1.0	1.0	1.0	-	-	-	-
RUPEX	NBR	-30	-	1.0	1.0	1.0	1.0	1.0	-	-	-	-
RUPEX	NR	-50	1.1	1.0	-	-	-	-	-	-	-	-
RUPEX	HNBR	-10	-	1.0	1.0	1.0	1.0	1.0	1.25	1.25	-	-
N-BIPEX	TPU	-50	1.0	1.0	1.0	1.0	1.0	1.0	1.0	1.0	-	-
ELPEX	NR	-40	1.1	1.0	1.25	1.40	1.60	-	-	-	-	-
ELPEX-B	NR	-50	1.1	1.0	-	-	-	-	-	-	-	-
ELPEX-B	CR	-15	-	1.0	1.0	1.0	-	-	-	-	-	-
ELPEX-S SN, NN, WN	NR	-40	1.1	1.0	1.25	1.40	1.60	-	-	-	-	-
ELPEX-S NX	VMQ	-40	1.1	1.0	1.0	1.0	1.0	1.0	1.1	1.25	1.4	1.6

- NR = natural rubber, natural-synthetic rubber mixture
- NBR = nitril-butadiene-rubber (Perbunan)
- HNBR = hydrated acrylonitrile butadiene rubber
- CR = chloroprene rubber (FRAS fire-resistant and anti-static)
- VMQ = silicone
- TPU = polyurethane

¹⁾ The N-EUPEX coupling is not suitable for shock loads when used at low temperatures.

Coupling size $T_{KN} \geq T_N \cdot FB \cdot FT$

In the case of ARPEX and ZAPEX coupling types, no temperature factor (FT = 1.0) need be taken into account.

Coupling load at maximum and overload conditions

The maximum torque is the highest load acting on the coupling in normal operation. Maximum torques at a frequency of up to 25 times an hour are permitted and must be lower than the maximum coupling torque. Examples of maximum torque conditions are: Starting operations, stopping operations or usual operating conditions with maximum load.

$T_{Kmax} \geq T_{Max} \cdot FT$

Overload torques are maximum loads which occur only in combination with special, infrequent operating conditions. Examples of overload torque conditions are: Motor short circuit, emergency stop or blocking because of component breakage. Overload torques at a frequency of once a month are permitted and must be lower than the maximum overload torque of the coupling. The overload condition may last only a short while, i.e. fractions of a second.

$T_{KOL} \geq T_{OL} \cdot FT$

Coupling load due to dynamic torque load

Applying the frequency factor FF, the dynamic torque load must be lower than the coupling fatigue torque.

Dynamic torque load

$T_{KW} \geq T_W \cdot FF$

Frequency of the dynamic torque load $f_{err} \leq 10$ Hz frequency factor FF = 1.0

Frequency of the dynamic torque load $f_{err} > 10$ Hz frequency factor FF = $\sqrt{(f_{err}/10 \text{ Hz})}$

For the ZAPEX and ARPEX series, the frequency factor is always FF = 1.0.

SELECTION OF THE COUPLING SIZE

E

Checking the maximum speed

For all load situations $n_{K_{max}} \geq n_{max}$

Checking permitted shaft misalignment

For all load situations, the actual shaft misalignment must be less than the permitted shaft misalignment.

Checking bore diameter, mounting geometry and coupling design

The check must be made on the basis of the dimension tables. The maximum bore diameter applies to parallel keyways to DIN 6885. For other keyway geometries, the maximum bore diameter can be reduced.

On request, couplings with adapted geometry can be provided.

Coupling behavior under overload conditions

The ZAPEX, N-ARPEX, ARPEX, N-EUPEX, RUPEX and N-BIPEX coupling series can withstand overloads until the breakage of metal parts. These coupling series are designated as fail-safe.

The N-EUPEX DS, ELPEX-B, ELPEX-S and ELPEX coupling series throw overload. The elastomer element of these couplings is irreparably damaged without damage to metal parts when subjected to excessive overload.

These coupling series are designated as non-fail-safe. These types that fail can be fitted with a so-called fail-safe device. This additional component enables emergency operation, even after the rubber element of the coupling has been irreparably damaged.

Checking shaft-hub connection

The torques specified in the tables of power ratings data of the coupling series do not necessarily apply to the shaft-hub connection. Depending on the shaft-hub connection, proof of form stability is required. Flender recommends obtaining proof of form strength by using calculation methods in accordance with the current state of the art.

Fitting recommendations for the shaft-hub connection are given in the **Appendix**.

The coupling hub is frequently fitted flush with the shaft end face. If the shaft projects, the risk of collision with other coupling parts must be checked. If the shaft is set back, in addition to the load-bearing capacity of the shaft-hub connection, the correct positioning of the hub must be ensured as well. If the bearing hub length is insufficient, restorative forces may cause tilting movements and so wear to and impairment of the axial retention. Also, the position of the set screw to be positioned on sufficient shaft or parallel key material must be noted.

Shaft-hub connection	Suggestion for calculation method
Keyway connection to DIN 6885-1	DIN 6892
Shrink fit	DIN 7190
Spline to DIN 5480	
Bolted flange connection	VDI 2230
Flange connection with close-fitting bolts	

Checking low temperature and chemically aggressive environment

The minimum permitted coupling temperature is specified in the Temperature factor FT table. In the case of chemically aggressive environments, please consult the manufacturer.

FEATURES OF THE STANDARD TYPE



Couplings	Features of the standard type
All coupling series except ARPEX clamping hubs and FLUDEX with keyway to ASME B17.1	Bore tolerance H7
N-ARPEX and ARPEX clamping hubs	Bore tolerance H6
FLUDEX couplings with keyway to ASME B17.1	Hollow shafts: bore tolerance K7 other parts: Bore tolerance M7
All coupling series with bore diameter - imperial	Parallel keyway to ASME B17.1
Bore diameter metric in the case of ZAPEX, N-ARPEX and ARPEX coupling series as well as coupling hubs with applied brake disks or brake drums of the N-EUPEX and RUPEX series	Parallel keyway to DIN 6885-1 keyway width P9
Bore diameter metric in the case of the N-EUPEX, RUPEX, N-BIPEX, ELPEX-S, ELPEX-B, ELPEX, FLUDEX coupling series	Parallel keyway to DIN 6885-1 keyway width JS9
All coupling series except FLUDEX	Axial locking by means of set screw
FLUDEX coupling series	Axial lock by means of set screw or end washer
All coupling series	Balancing in accordance with half parallel key standard
ZAPEX, N-ARPEX, ARPEX, N-EUPEX, RUPEX, N-BIPEX, ELPEX-S, ELPEX-B and ELPEX coupling series	Balancing quality G16
FLUDEX coupling series	Balancing quality G6.3
All series	Unpainted
All series	Preservation with cleaning emulsion
FLUDEX couplings	Fuse 140 °C

Configurator

The article number can be obtained with the help of the Configurator. The coupling can be selected in a product configurator and specified using selection menus.

The coupling can be selected via "Technical selection" (technical selection) or via "Direct selection" (via article-no.).

The Configurator is available under flender.com.

FLEXIBLE COUPLINGS – N-EUPEX, N-EUPEX DS SERIES

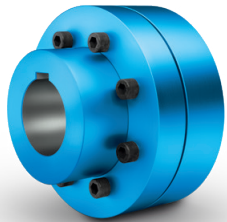

General	7/2
Benefits	7/2
Application	7/2
Design and configurations	7/3
Function	7/5
Modular principle of N-EUPEX types	7/6
N-EUPEX technical specifications	7/8
N-EUPEX DS technical specifications	7/10
Assignment of N-EUPEX sizes to IEC standard motors ¹⁾	7/12
Type A for easy elastomer flexible replacement	7/14
Type B	7/16
Type H	7/18
Type D for easy elastomer flexible replacement	7/20
Type E	7/22
Type P with brake drum	7/24
Type O with brake drum	7/26
Type DBDR with brake disk	7/28
Type DBD with brake disk	7/30
Type EBD with brake disk	7/32
Type ADS	7/34
Type BDS	7/35
Type HDS	7/36
Spare and wear parts	7/38



N-EUPEX
FLENDER

GENERAL

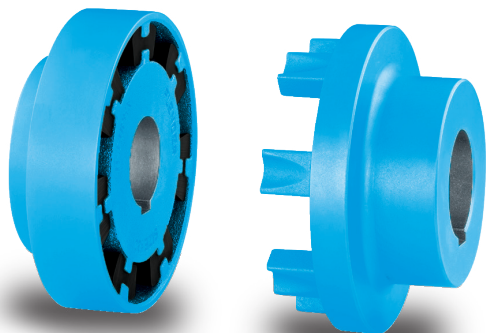

7 N-EUPEX as overload-holding, fail-safe series

N-EUPEX and N-EUPEX DS pin couplings connect machines. They compensate for shaft misalignment, generating only low restorative forces. The torque is conducted through elastomer flexibles, so the coupling has typically flexible rubber properties.

N-EUPEX couplings are overload-holding. By contrast, the N-EUPEX DS series is designed so that overload or advanced wear causes irreparable damage to the elastomer flexibles. The metal parts of N-EUPEX DS couplings can then rotate freely against one another without contact.

Benefits

N-EUPEX couplings are designed on the modular principle and have a very simple construction. N-EUPEX types are made up of subassemblies to suit requirements. The couplings are assembled by simply fitting the coupling halves together. Wear is restricted to the elastomer flexibles, which must be replaced at the end of their service life.

Application

The N-EUPEX coupling is available as a catalog standard in 23 sizes with a rated torque of between 19 Nm and 62000 Nm. The coupling is suitable for use at ambient temperatures of between -30 °C and +80 °C. By using alternative elastomer buffers, the permissible ambient temperature range can be extended to between -50 °C and +100 °C. Frequently, the coupling is used to connect the motor to the gear unit input shaft. The coupling is suitable especially for drives with uniform to average dynamic loads.

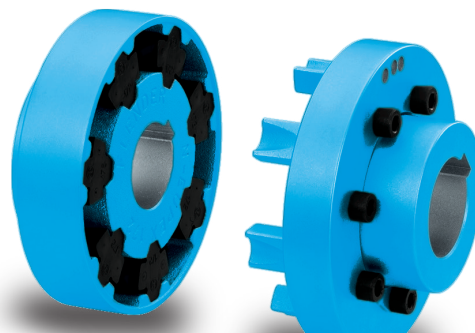

N-EUPEX DS as overload-shedding, non-fail-safe series



Coupling suitable for use in potentially explosive atmospheres.

Complies with the current ATEX Directive for:

CE II 2G Ex h IIC T6 ... T4 Gb X

II 2D Ex h IIIC T85 °C ... 110 °C Db X

I M2 Ex h Mb X

Depending on type, the elastomer flexibles can be changed without moving the coupled machines. The coupling parts are readily available from stock and are mostly finish-machined, i.e. with finished bore, keyway, set screw and balancing.

Examples of applications are pump drives, ventilator drives or crane running gear. Furthermore, N-EUPEX couplings can be used as add-on couplings, particularly on FLUDEX fluid couplings or ARPEX AKR safety couplings. In the case of drives with a diesel engine, N-EUPEX couplings are suitable for driven machines with a low mass moment of inertia. In the case of diesel engine drives, the actual dynamic coupling load should be checked by measurement or torsional vibration calculations.

Design and configurations

N-EUPEX and N-EUPEX DS couplings consist of two hub parts mounted on the machine shafts. The coupling parts are connected positively by means of elastomer flexibles. On the two-part variant, the elastomer flexibles can be changed only if one of the coupled machines is moved.

On the three-part variants, the bolted cam ring can be released and moved to enable the flexible to be changed without moving the coupled machines.

Elastomer flexible of the N-EUPEX series



The flexibles of the N-EUPEX coupling are subjected to compression. If the flexibles are irreparably damaged, the hub parts come into contact with metal. This "emergency operation capability" is required, e.g., in the case of fire pump drives.

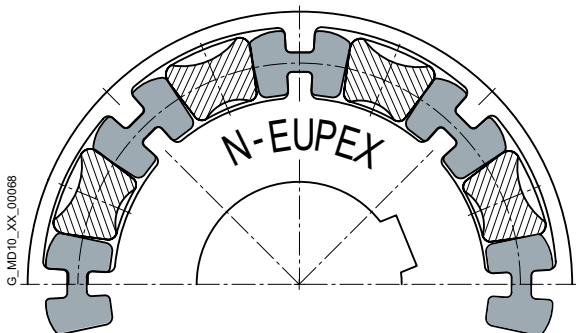

Elastomer flexible of the N-EUPEX DS series



The flexibles of the N-EUPEX DS series are subjected to compression and bending forces. If the flexibles are irreparably damaged, the metal parts turn against one another without contact, and the power transmission is separated. Fitting new flexibles will make the coupling once more usable.

The capacity of the N-EUPEX DS series to shed overloads is especially in demand for highly sensitive machines.

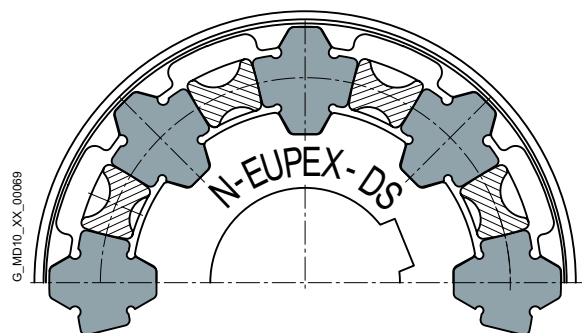

GENERAL

Materials

- Cam parts, pocket parts, adapters and hubs:
Grey cast iron EN-GJL-250
- Brake disks:
EN-GJS-400 spheroidal graphite cast iron or S355J2G3 steel
- Brake drums:
Grey cast iron EN-GJL-250
- Low-temperature application:
Shock loads in the drive caused by e.g. starting of drives with large masses to be accelerated (e.g. in fan drives) result in high component loads, particularly at low temperatures. For such applications a particularly robust coupling series must be selected. Of the flexible couplings, the RUPEX pin-and-bush coupling is especially suited for this.

Flexible materials

Material/description	Hardness	Marking	Ambient temperature
N-EUPEX series			
NBR standard type	80 ShoreA	Flexible black with blue stripe	-30 °C ... +80 °C
NBR electrically insulating	80 ShoreA	Flexible green	-30 °C ... +80 °C
NBR soft	65 ShoreA	Flexible black with green stripe	-30 °C ... +80 °C
NBR hard	90 ShoreA	Flexible black with magenta stripe	-30 °C ... +80 °C
NBR normal low-backlash	80 ShoreA	Flexible black with yellow stripe	-30 °C ... +80 °C
NBR soft low-backlash	65 ShoreA	Flexible black with white stripe	-30 °C ... +80 °C
NR for low temperature	80 ShoreA	Flexible black with orange stripe	-50 °C ... +50 °C
HNBR high temperature	80 ShoreA	Flexible black with red stripe	-10 °C ... +100 °C
N-EUPEX DS series			
NBR hard	90 ShoreA	Flexible black	-30 °C ... +80 °C

- The technical data and article numbers do not include the flexible variants NBR low-backlash, HNBR high temperature and NR low temperature.
- Technical data, prices and article numbers on request.

Types of N-EUPEX pin coupling

Type	Description
A	Fail-safe, 3-part
B	Fail-safe, 2-part
D	Fail-safe, 3-part, flange variant
E	Fail-safe, 2-part, flange variant
H	Fail-safe, with adapter
O	Fail-safe, 2-part, with brake drum
P	Fail-safe, 3-part, with brake drum
EBD	Fail-safe, 2-part, with brake disk
DBD	Fail-safe, 3-part, with brake disk
DBDR	Fail-safe, 3-part, with brake disk, brake disk radially dismountable
ADS	Non-fail-safe, 3-part
BDS	Non-fail-safe, 2-part
HDS	Non-fail-safe, with adapter

Types of N-EUPEX pin coupling on request

Type	Description
AT	Fail-safe, 3-part, with Taper clamping bush
BT	Fail-safe, 2-part, with Taper clamping bush
G	Fail-safe, 2-part, with intermediate shaft
F	Fail-safe, 3-part, with intermediate shaft
K	Fail-safe, 3-part, with brake drum to customer's requirement
L	Fail-safe, 2-part, with brake drum to customer's requirement
M	Fail-safe, 2-part, with flange dimensions to SAE J620d

Further application-related coupling types are available. Dimension sheets for and information on these are available on request.

Function

The motor torque is transmitted to the hub on the drive side via the shaft-hub connection, which is mostly designed as a keyway connection. The torque is transmitted to the hub on the output side with the aid of elastomer flexibles. The hub on the output side further transmits the torque to the driven machine or a gear unit placed in between. Because of the primarily compression-loaded elastomer flexibles, the coupling has a progressive torsional stiffness. In the case of the N-EUPEX DS coupling series, the elastomer flexible is subjected to bending and compression loads.

In the event of overload or advanced wear, the coupling disconnects positively and the flexibles are irreparably damaged.

The metal parts then rotate without touching one another. After new elastomer flexibles are fitted, the N-EUPEX DS coupling is once more operable.

N-EUPEX DS couplings are maintenance-free, even in potentially explosive environments, so long as the possible torque interruption does not lead to an unacceptable disruption of the production process.

Wear indicator for N-EUPEX couplings (optional)

The wear indicator for N-EUPEX couplings enables the condition of the flexible to be easily assessed. The wear condition can also be ascertained with the aid of a stroboscope while the coupling is rotating. The production process can thus continue undisturbed.

If the stroboscope is to be used in a potentially explosive environment, you can enquire about the equipment for this at Flender.

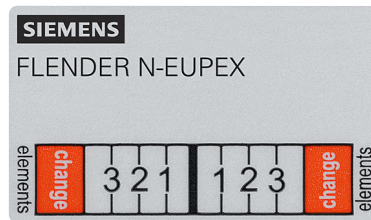

Pocket part
(part 1, 10)



Cam part
(part 3, 4, 7)

The wear indicator must be attached to the outside diameter of the coupling after the coupling has been fitted.

GENERAL

Modular principle of N-EUPEX types

7

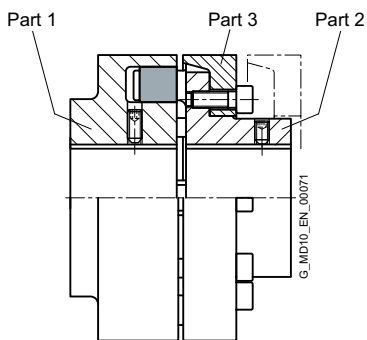
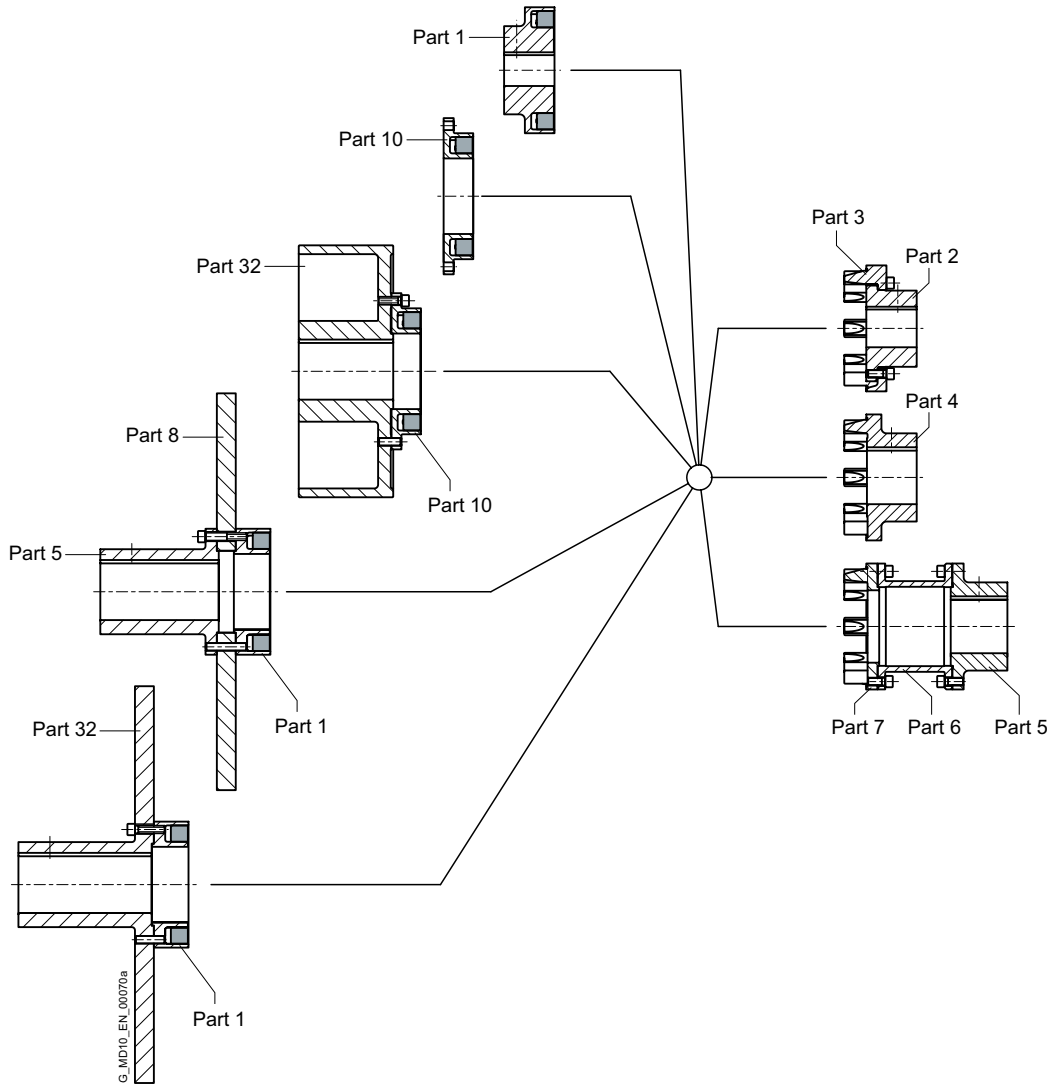

Types A and ADS

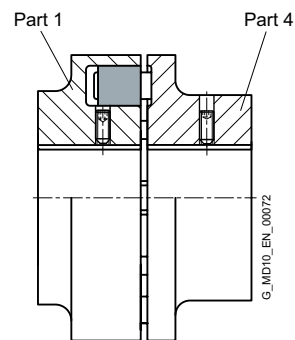

Types B and BDS

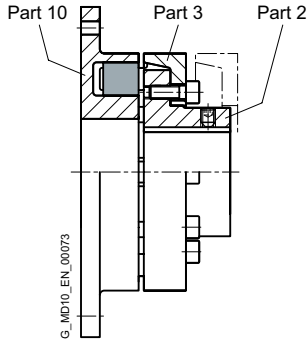

Type D

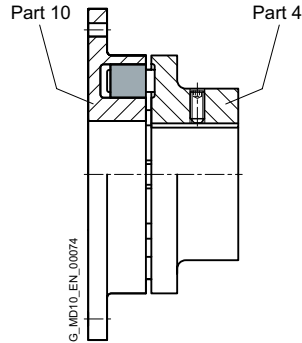

Type E

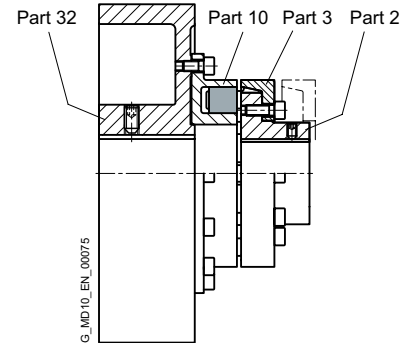

Type P

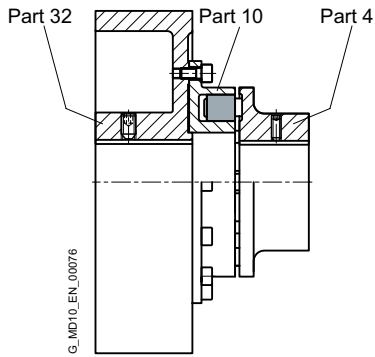

Type O

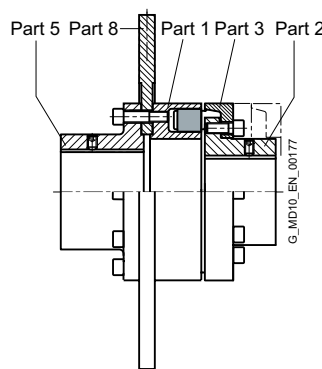

Type DBDR

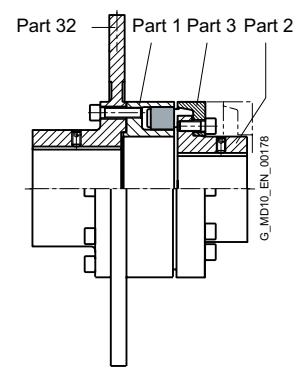

Type DBD

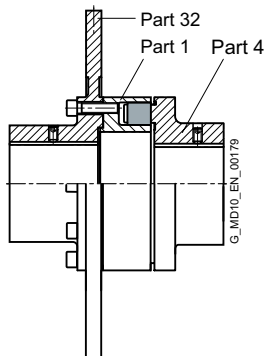

Type EBD

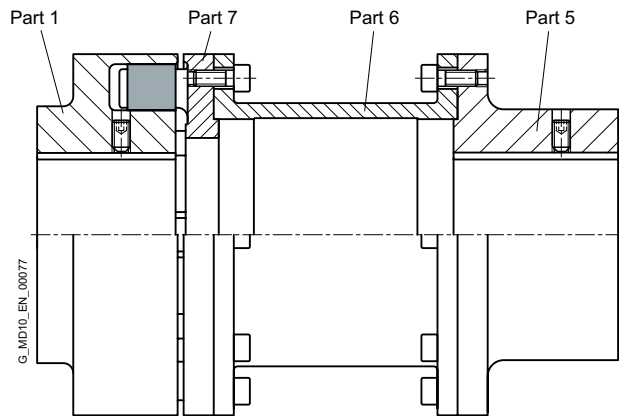

Types H and HDS

Note

- Further application-related coupling types are available. Dimension sheets for and information on these are available on request.

GENERAL

N-EUPEX technical specifications

Power ratings of the N-EUPEX series									
Size	Rated torque for flexible type			Torsional stiffness at 50 % capacity utilization for flexible type			Assembly Gap dimension ²⁾ ΔS mm	Permitted shaft misalignment at $n = 1500$ rpm ¹⁾	
	65 ShoreA T_{KN} Nm	80 ShoreA T_{KN} Nm	90 ShoreA T_{KN} Nm	65 ShoreA C_{Tdyn} 50 % kNm/rad	80 ShoreA C_{Tdyn} 50 % kNm/rad	90 ShoreA C_{Tdyn} 50 % kNm/rad		Radial ΔK_r mm	Angle ΔK_w °
58	11	19	19	0.21	0.50	0.93	1.0	0.2	0.15
68	21	34	34	0.39	0.90	1.80	1.0	0.2	0.15
80	37	60	60	1.05	2.40	4.50	1.0	0.2	0.12
95	63	100	100	1.64	4.00	7.40	1.0	0.2	0.12
110	100	160	160	2.49	6.00	11.4	1.0	0.2	0.10
125	150	240	240	3.70	9.00	17	1.0	0.25	0.10
140	230	360	360	5.60	13.2	25	1.0	0.25	0.10
160	350	560	560	11.2	26.7	51	2.0	0.3	0.10
180	550	880	880	19.2	46	88	2.0	0.3	0.10
200	850	1340	1340	31.6	75	139	2.0	0.3	0.09
225	1260	2000	2000	48	115	212	2.0	0.35	0.09
250	1760	2800	2800	68	162	302	2.5	0.35	0.08
280	2460	3900	3900	95	226	420	2.5	0.4	0.08
315	3500	5500	5500	171	370	730	2.5	0.4	0.08
350	4850	7700	7700	235	520	950	2.5	0.5	0.08
400	6500	10300	10300	316	750	1420	2.5	0.5	0.08
440	8500	13500	13500	390	930	1920	2.5	0.6	0.08
480	10500	16600	16600	510	1200	2300	2.5	0.6	0.07
520	13300	21200	21200	600	1410	2710	2.5	0.65	0.07
560	18300	29000	29000	1000	2340	4400	3.0	0.65	0.07
610	24000	38000	38000	1300	3030	5700	3.0	0.75	0.07
660	30900	49000	49000	1640	3800	7100	3.0	0.8	0.07
710	39000	62000	62000	2140	4900	9100	3.0	0.9	0.07

For maximum coupling torque:

$$T_{Kmax} = 3,0 \cdot T_{KN}$$

For coupling overload torque:

$$T_{KOL} = 3.5 \cdot T_{KN}$$

For coupling fatigue torque:

$$T_{KW} = 0,15 \cdot T_{KN}, \text{ where } T_N > T_W \text{ must be adhered to.}$$

Note

For fitting, the maximum gap dimension of $S_{max} = S + \Delta S$ and the minimum gap dimension of $S_{min} = S - \Delta S$ are permitted.

¹⁾ The maximum speed for the respective type must be noted.
For additional information on the allowable shaft misalignment, please refer to the operating instructions.

²⁾ Does not apply to type H.
The ΔS clearance for types DBDR and DBD (coupling sizes 250, 280, 315 and 350), as well as for type EBD (coupling sizes 250 and 280) is +2/-3 mm.

Torsional stiffness and damping

The values stated in the above table apply to a capacity utilization of 50 %, an excitation amplitude of 10 % T_{KN} with the frequency 10 Hz and an ambient temperature of 20 °C. The dynamic torsional stiffness is load-dependent and increases in proportion to capacity utilization. The following table shows the correction factors for different rated loads.

$$C_{Tdyn} = C_{Tdyn\ 50\%} \cdot FKC$$

	Load T_N / T_{KN}						
	20%	40%	50%	60%	70%	80%	100%
Correction factor FKC 65/80/90 ShoreA	0.54	0.84	1.00	1.18	1.36	1.55	1.97

The damping coefficient is $\Psi = 1.4$

Torsional stiffness and damping is further dependent on the ambient temperature and the frequency and amplitude of the torsional vibration excitation. More precise torsional stiffness and damping parameters on request.

With flexible couplings the manufacturing process of the rubber elements and their aging primarily influence the stiffness value C_{Tdyn} . For this reason calculation must be made with a tolerance for the dynamic stiffness of $\pm 20\%$. The specified damping coefficient Ψ is a minimum value with the result that the damping performance of the coupling corresponds at least to the specified value.

Permitted shaft misalignment

The permitted shaft misalignment depends on the operating speed. As the speed increases, lower shaft misalignment values are permitted. The correction factors for different speeds are specified in the following table. The maximum speed for the respective coupling size must be noted!

$$\Delta K_{perm} = \Delta K_{1500} \cdot FKV$$

	Speed in rpm			
	500	1000	1500	3000
Correction factor FKV	1.7	1.2	1.0	0.7

For fitting, the maximum gap dimension of $S_{max.} = S + \Delta S$ and the minimum gap dimension of $S_{min.} = S - \Delta S$ are permitted.

Shaft misalignments ΔK_r and ΔK_w may occur simultaneously.

GENERAL

N-EUPEX DS technical specifications

Power ratings of the N-EUPEX DS series					
Size	Rated torque		Assembly Gap dimension ¹⁾ ΔS mm	Permitted shaft misalignment at speed $n = 1500$ rpm	
	T_{KN} Nm	Torsional stiffness at 50 % capacity utilization C_{Tdyn} kNm/rad		Radial ΔK_r mm	Angle ΔK_w °
66	19	0.73	1.0	0.2	0.15
76	34	1.36	1.0	0.2	0.15
88	60	2.62	1.0	0.2	0.12
103	100	4.00	1.0	0.2	0.12
118	160	6.30	1.0	0.2	0.10
135	240	10.5	1.0	0.25	0.10
152	360	13.6	1.0	0.25	0.10
172	560	27.2	2.0	0.3	0.10
194	880	47.0	2.0	0.3	0.10
218	1340	70.0	2.0	0.3	0.09
245	2000	106	2.0	0.35	0.09
272	2800	149	2.5	0.35	0.08
305	3900	214	2.5	0.4	0.08
340	5500	350	2.5	0.4	0.08
380	7700	480	2.5	0.5	0.08
430	10300	730	2.5	0.5	0.08
472	13500	990	2.5	0.6	0.08
514	16600	1270	2.5	0.6	0.07
556	21200	1540	2.5	0.65	0.07

For maximum coupling torque:

$$T_{Kmax} = 2,0 \cdot T_{KN}$$

For coupling overload torque:

$$T_{KOL} = 3,0 \cdot T_{KN}$$

For coupling fatigue torque:

$$T_{KW} = 0,15 \cdot T_{KN}$$

Note

For fitting, the maximum gap dimension of
S max. = S + ΔS and the minimum gap dimension of
S min. = S - ΔS are permitted.

¹⁾ Does not apply to type HDS.

Torsional stiffness and damping

The values stated in the above table apply to a capacity utilization of 50 %, an excitation amplitude of 10 % T_{KN} with the frequency 10 Hz and an ambient temperature of 20 °C. The dynamic torsional stiffness is load-dependent and increases in proportion to capacity utilization. The following table shows the correction factors for different rated loads.

$$C_{Tdyn} = C_{Tdyn\ 50\%} \cdot FKC$$

	Load T_N / T_{KN}						
	20%	40%	50%	60%	70%	80%	100%
Correction factor FKC	0.7	0.9	1	1.1	1.2	1.3	1.5

The damping coefficient is $\Psi = 1.4$

Torsional stiffness and damping is further dependent on the ambient temperature and the frequency and amplitude of the torsional vibration excitation. More precise torsional stiffness and damping parameters on request.

With flexible couplings the manufacturing process of the rubber elements and their aging primarily influence the stiffness value C_{Tdyn} . For this reason calculation must be made with a tolerance for the dynamic stiffness of $\pm 20\%$. The specified damping coefficient Ψ is a minimum value with the result that the damping performance of the coupling corresponds at least to the specified value.

Permitted shaft misalignment

The permitted shaft misalignment depends on the operating speed. As the speed increases, lower shaft misalignment values are permitted. The correction factors for different speeds are specified in the following table. The maximum speed for the respective coupling size must be noted!

$$\Delta K_{perm} = \Delta K_{1500} \cdot FKV$$

	Speed in rpm			
	500	1000	1500	3000
Correction factor FKV	1.7	1.2	1.0	0.7

For fitting, the maximum gap dimension of $S_{max.} = S + \Delta S$ and the minimum gap dimension of $S_{min.} = S - \Delta S$ are permitted.

Shaft misalignments ΔK_r and ΔK_w may occur simultaneously.

GENERAL

Assignment of N-EUPEX sizes to IEC standard motors ¹⁾

Three-phase motor Size	Motor output at ≈ 3000 rpm	N-EUPEX coupling	Motor output at ≈ 1500 rpm	N-EUPEX coupling	Motor output at ≈ 1000 rpm	N-EUPEX coupling	Motor output at ≈ 750 rpm	N-EUPEX coupling	DE shaft end D x E acc. to IEC	
	P_M kW	Size	P_M kW	Size	P_M kW	Size	P_M kW	Size	D mm	E mm
56	0.09	58	0.06	58					9	20
	0.12	58	0.09	58						
63	0.18	58	0.12	58					11	23
	0.25	58	0.18	58						
71	0.37	58	0.25	58					14	30
	0.55	58	0.37	58						
80	0.75	58	0.55	58	0.37	58			19	40
	1.1	58	0.75	58	0.55	58				
90 S	1.5	68	1.1	68	0.75	68			24	50
90 L	2.2	68	1.5	68	1.1	68			24	50
100 L	3	80	2.2	80	1.5	80	0.75	80	28	60
			3	80			1.1	80		
112 M	4	80	4	80	2.2	80	1.5	80	28	60
132 S	5.5	95	5.5	95	3	95	2.2	95	38	80
	7.5	95								
132 M			7.5	95	4	95	3	95	38	80
					5.5	95				
160 M	11	95	11	95	7.5	95	4	95	42	110
	15	95					5.5	95		
160 L	18.5	95	15	110	11	110	7.5	110	42	110
180 M			18.5	110					48	110
180 L	22	110	22	125	15	125	11	125	48	110
200 L	30	125	30	125	18.5	125	15	125	55	110
	37	125			22	140				

¹⁾ The assignment applies to an application factor of 1.25.
Outputs P_M of IEC motors and assigned N-EUPEX couplings

Three-phase motor Size	Motor Output at ≈ 3000 rpm	N-EUPEX coupling Size	Motor Output at ≈ 1500 rpm	N-EUPEX coupling Size	Motor Output at ≈ 1000 rpm	N-EUPEX coupling Size	Motor Output at ≈ 750 rpm	N-EUPEX coupling Size	DE shaft end D x E acc. to IEC	
	P_M kW		P_M kW		P_M kW		P_M kW		D mm	E mm
225 S			37	140			18.5	140	55	110
									60	140
225 M	45	125	45	140	30	140	22	140	55	110
									60	140
250 M	55	140	55	160	37	160	30	160	60	140
									65	140
280 S	75	160	75	180	45	180	37	180	65	140
									75	140
280 M	90	160	90	180	55	180	45	180	65	140
									75	140
315 S	110	160	110	200	75	200	55	200	65	140
									80	170
315 M	132	160	132	200	90	200	75	200	65	140
									80	170
315 L	160	180							65	140
	200	180							65	140
			160	200	110	200	90	225	80	170
			200	225	132	225	110	225	80	170
315					160	225	132	250	85	170
	250	200							65	140
	315	200							65	140
355			250	225	200	250			85	170
	355	225								
355	400	225							75	140
	500	225								

TYPE A

for easy elastomer flexible replacement

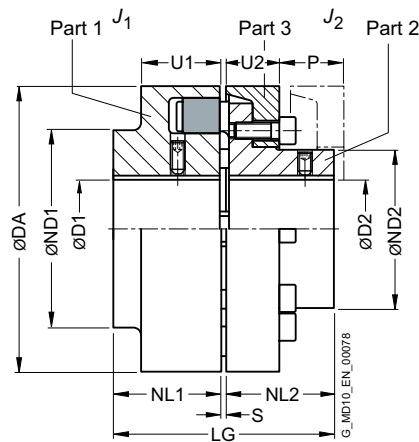

Size	Rated torque flexible type 80 ShoreA T_{KN} Nm	Speed n_{Kmax} rpm	Dimensions in mm Bore with keyway to DIN 6885											Mass moment of inertia J_1/J_2 kgm ²	➤ Article no. ¹⁾	Weight m kg		
			D1		D2		DA	ND1	ND2	NL1/ NL2	S	U1	U2				P	LG
			min.	max.	min.	max.												
110	160	5300	-	48	-	38	110	86	62	40	3	34	20	33	83	0.003	2LC0100-4AB	3
125	240	5100	-	55	-	45	125	100	75	50	3	36	23	38	103	0.005	2LC0100-5AB	4.8
140	360	4900	-	60	-	50	140	100	82	55	3	34	28	43	113	0.008	2LC0100-6AB	6
160	560	4250	-	65	-	58	160	108	95	60	4	39	28	47	124	0.014	2LC0100-7AB	8.4
180	880	3800	-	75	-	65	180	125	108	70	4	42	30	50	144	0.025	2LC0100-8AB	12
200	1340	3400	-	85	-	75	200	140	122	80	4	47	32	53	164	0.04	2LC0101-0AB	17
225	2000	3000	-	90	-	85	225	150	138	90	4	52	38	61	184	0.08	2LC0101-1AB	23
250	2800	2750	46	100	-	95	250	165	155	100	5.5	60	42	69	205.5	0.13	2LC0101-2AB	31
280	3900	2450	49	110	54	105	280	180	172	110	5.5	65	42	73	225.5	0.20	2LC0101-3AB	41
315	5500	2150	49	100	46	100	315	165	165	125	5.5	70	47	78	255.5	0.32	2LC0101-4AB	57
			90	120	90	120		200	200							0.35		61
350	7700	2000	61	110	61	110	350	180	180	140	5.5	74	51	83	285.5	0.54	2LC0101-5AB	78
			90	140	90	140		230	230							0.61		82
400	10300	1700	66	120	66	120	400	200	200	160	5.5	78	56	88	325.5	1.0	2LC0101-6AB	112
			100	150	100	150		250	250							1.1		117

Configurable variants ¹⁾

- ØD1 Without finished bore
With finished bore
- ØD2 Without finished bore
With finished bore

¹⁾ To identify complete item numbers specifying the available finish boring options and – if necessary – further order options, please use our configurators on flender.com.

➤ For online configuration on flender.com, click on the item no.

Size	Rated torque flexible type 80 ShoreA T_{KN} Nm	Speed n_{Kmax} rpm	Dimensions in mm													Mass moment of inertia J_1/J_2 kgm ²	Article no. ¹⁾	Weight m kg
			Bore with keyway to DIN 6885				DA	ND1	ND2	NL1/NL2	S	U1	U2	P	LG			
			D1		D2													
min.	max.	min.	max.															
440	13500	1550	80	130	80	130	440	215	215	180	7.5	86	64	99	367.5	1.5	2LC0101-7AB	147
			120	160	120	160		265	265							1.7		155
480	16600	1400	90	145	90	145	480	240	240	190	7.5	90	65	104	387.5	2.3	2LC0101-8AB	184
			136	180	136	180		300	300							2.6		200
520	21200	1300	100	150	100	150	520	250	250	210	7.5	102	68	115	427.5	3.3	2LC0102-0AB	234
			140	190	140	190		315	315							3.7		254
560	29000	1200	120	200	120	200	560	320	320	220	9	115	80	125	449	6.0	2LC0102-1AB	329
610	38000	1100	130	220	130	220	610	352	352	240	9	121	88	135	489	9.0	2LC0102-2AB	416
660	49000	1000	140	240	140	240	660	384	384	260	9	132	96	145	529	13.5	2LC0102-3AB	546
710	62000	1000	140	260	140	260	710	416	416	290	9	138	102	155	589	19	2LC0102-4AB	680

Configurable variants¹⁾

- ØD1 Without finished bore
With finished bore

- ØD2 Without finished bore
With finished bore

Notes

- The hub diameter of the component part is assigned according to the diameter of the finished bore. Where bore diameters overlap, the component with the smaller hub diameter is always selected.
- Weights and mass moments of inertia apply to maximum bore diameters.
- The article numbers apply to standard flexibles of 80 ShoreA; the article no. for alternative flexible types is available on request.

Ordering example

- ZN-EUPEX A coupling, size 200
- Part 1: Bore D1 65H7 mm, keyway to DIN 6885-1 and set screw
- Part 2: Bore D2 50H7 mm, keyway to DIN 6885-1 and set screw

Article no.: 2LC0101-0AB99-0AA0-Z L1F+M1C

¹⁾ To identify complete item numbers specifying the available finish boring options and – if necessary – further order options, please use our configurators on flender.com.

↗ For online configuration on flender.com, click on the item no.

TYPE B

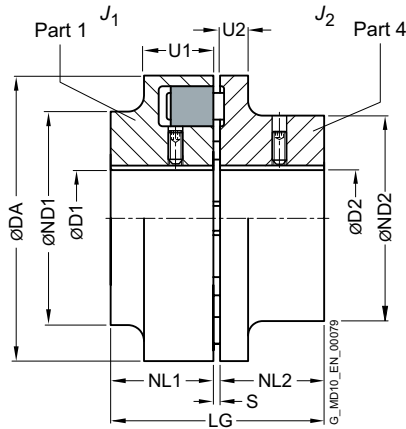

Size	Rated torque flexible type 80 ShoreA T_{KN} Nm	Speed n_{Kmax} rpm	Dimensions in mm											Mass moment of inertia J_1/J_2 kgm ²	➤ Article no. ¹⁾	Weight m kg	
			Bore with keyway to DIN 6885				DA	ND1	ND2	NL1/ NL2	S	U1	U2				LG
			D1		D2												
58	19	7500	-	19	-	24	58	58	40	20	3	20	8	43	0.0001	2LC0100-0AA	0.4
68	34	7000	-	24	-	28	68	68	50	20	3	20	8	43	0.0002	2LC0100-1AA	0.54
80	60	6000	-	30	-	38	80	80	68	30	3	30	10	63	0.0006	2LC0100-2AA	1.3
95	100	5500	-	42	-	42	95	76	76	35	3	30	12	73	0.0013	2LC0100-3AA	2.2
110	160	5300	-	48	-	48	110	86	86	40	3	34	14	83	0.003	2LC0100-4AA	3.3
125	240	5100	-	55	-	55	125	100	100	50	3	36	18	103	0.006	2LC0100-5AA	5.2
140	360	4900	-	60	-	60	140	100	100	55	3	34	20	113	0.007	2LC0100-6AA	5.6

Configurable variants¹⁾

- ØD1 Without finished bore
With finished bore
- ØD2 Without finished bore
With finished bore

¹⁾ To identify complete item numbers specifying the available finish boring options and – if necessary – further order options, please use our configurators on flender.com.

➤ For online configuration on flender.com, click on the item no.

Size	Rated torque flexible type 80 ShoreA T_{KN} Nm	Speed n_{Kmax} rpm	Dimensions in mm Bore with keyway to DIN 6885											Mass moment of inertia J_1/J_2 kgm ²	➤ Article no. ¹⁾	Weight m kg	
			D1		D2		DA	ND1	ND2	NL1/ NL2	S	U1	U2				LG
			min.	max.	min.	max.											
160	560	4250	-	65	-	65	160	108	108	60	4	39	20	124	0.01	2LC0100-7AA	7.8
180	880	3800	-	75	-	75	180	125	125	70	4	42	20	144	0.02	2LC0100-8AA	11.5
200	1340	3400	-	85	-	85	200	140	140	80	4	47	24	164	0.04	2LC0101-0AA	16
225	2000	3000	-	90	-	90	225	150	150	90	4	52	18	184	0.07	2LC0101-1AA	20
250	2800	2750	46	100	46	100	250	165	165	100	5.5	60	18	205.5	0.12	2LC0101-2AA	29
280	3900	2450	49	110	54	110	280	180	180	110	5.5	65	20	225.5	0.18	2LC0101-3AA	38

Configurable variants¹⁾

- ØD1 Without finished bore
With finished bore
- ØD2 Without finished bore
With finished bore

Notes

- Weights and mass moments of inertia apply to maximum bore diameters.
- The article numbers apply to standard flexibles of 80 ShoreA; the article no. for alternative flexible types is available on request.

Ordering example

- N-EUPEX B coupling, size 95
- Part 1: Bore D1 42H7 mm, keyway to DIN 6885-1 and set screw
- Part 2: Bore D2 32H7 mm, keyway to DIN 6885-1 and set screw

Article no.: 2LC0100-3AA99-0AA0-Z L0X+M0T

¹⁾ To identify complete item numbers specifying the available finish boring options and – if necessary – further order options, please use our configurators on flender.com.
➤ For online configuration on flender.com, click on the item no.

TYPE H

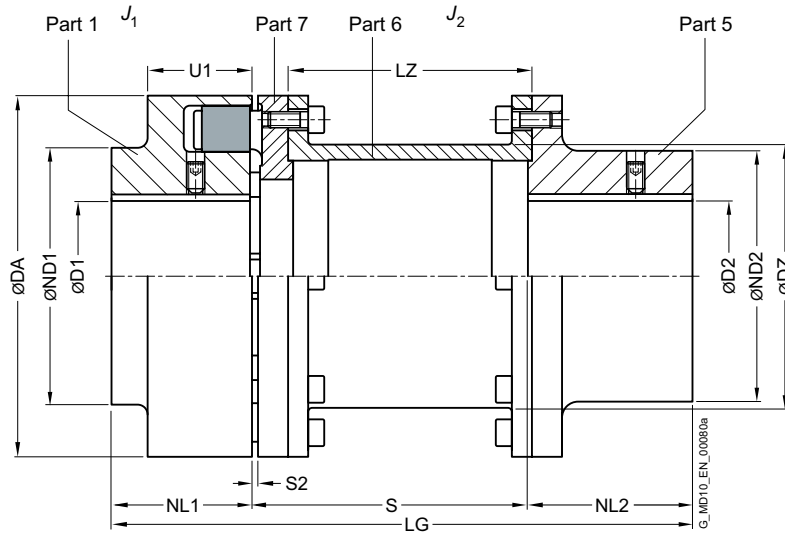

Size	Rated torque flexible type 80 ShoreA T_{KN} Nm	Speed n_{Kmax} rpm	Dimensions in mm													Mass moment of inertia		Article no. ¹⁾	Weight m kg
			Bore with keyway to DIN 6885 D1 min. max.		D2 min. max.		DA	ND1	ND2	NL1	NL2	S2	S	LZ	DZ	LG	J_1 kgm ²		
80	60	6000	-	30	-	32	80	80	55	30	45	5	100	87	175	0.0006	0.001	2LC0100-2AG	2.6
													140	127					
95	100	5500	-	42	-	42	95	76	70	35	45	5	100	87	180	0.001	0.003	2LC0100-3AG	3.5
													140	127					
110	160	5300	-	48	-	48	110	86	80	40	50	5	100	85	190	0.003	0.005	2LC0100-4AG	5.2
													50	140					
125	240	5100	-	55	-	55	125	100	90	50	60	5	180	165	280	0.005	0.011	2LC0100-5AG	8.2
													70	200					
140	360	4900	-	60	-	60	140	100	100	55	65	5	180	162	260	0.007	0.02	2LC0100-6AG	11.0
													65	200					
160	560	4250	-	65	-	65	160	108	108	60	70	6	180	161.5	230	0.013	0.03	2LC0100-7AG	13
													70	140					
													70	200	181.5	330	0.035	2LC0100-7AG	14.9
													80	250	231.5	390	0.037	2LC0100-7AG	15.9

Configurable variants ¹⁾

- ØD1 Without finished bore
With finished bore
- ØD2 Without finished bore
With finished bore

¹⁾ To identify complete item numbers specifying the available finish boring options and – if necessary – further order options, please use our configurators on flender.com.

↗ For online configuration on flender.com, click on the item no.

Size	Rated torque flexible type 80 ShoreA T_{KN} Nm	Speed n_{Kmax} rpm	Dimensions in mm													Mass moment of inertia		Article no. ¹⁾	Weight m kg
			Bore with keyway to DIN 6885				DA	ND1	ND2	NL1	NL2	S2	S	LZ	DZ	LG	J_1 kgm ²		
D1 min.	D1 max.	D2 min.	D2 max.																
180	880	3800	-	75	-	75	180	125	125	70	80	6	140	121.5	290	0.023	0.054	2LC0100-8AG	18.5
													180	161.5	330		0.058	2LC0100-8AG	19.4
													200	181.5	350		0.060	2LC0100-8AG	21
													250	231.5	400		0.065	2LC0100-8AG	22
200	1340	3400	-	85	-	85	200	140	140	80	90	6	140	118.5	310	0.04	0.095	2LC0101-0AG	25.6
													180	158.5	350		0.1	2LC0101-0AG	26.5
													200	178.5	370		0.105	2LC0101-0AG	27.2
													250	228.5	420		0.11	2LC0101-0AG	28.5
225	2000	3000	-	90	-	90	225	150	150	90	100	6	140	118.5	330	0.07	0.158	2LC0101-1AG	34
													180	158.5	370		0.16	2LC0101-1AG	35
													200	178.5	390		0.17	2LC0101-1AG	36
													250	228.5	440		0.18	2LC0101-1AG	38
250	2800	2750	46	100	46	100	250	165	165	100	110	8	180	152.5	390	0.12	0.27	2LC0101-2AG	48
													200	172.5	410		0.28	2LC0101-2AG	50
													250	222.5	460		0.3	2LC0101-2AG	52
													280	222.5	215		480	0.20	0.52
280	3900	2450	49	100	51	110	280	180	180	110	120	8	250	222.5	215	0.32	0.87	2LC0101-4AG	98
													250	222.5	250				515
315	5500	2150	90	120	51	120	315	165	200	125	140	8	250	222.5	250	0.54	1.4	2LC0101-5AG	120
													230	230	140				150
350	7700	2000	61	110	51	140	350	180	230	140	150	8	250	220.5	272	1.0	2.9	2LC0101-6AG	195
													250	220.5	272				540
400	10300	1700	66	120	51	150	400	200	250	160	180	8	250	185.5	310	1.5	4.1	2LC0101-7AG	225
													250	185.5	310				590
440	13500	1550	80	130	51	160	440	215	265	180	180	10	250	182	354	1.7	4.1	2LC0101-7AG	230
													250	182	354				610

Configurable variants¹⁾

- ØD1 Without finished bore
With finished bore
- ØD2 Without finished bore
With finished bore

Notes

- For dimension U1, see type A on Page 7/14.
- During assembly, the gap dimension S2 must not exceed the permissible tolerance of +1 mm.
- The hub diameter of the component part is assigned according to the diameter of the finished bore. Where bore diameters overlap, the component with the smaller hub diameter is always selected.
- Weights and mass moments of inertia apply to maximum bore diameters.
- The article numbers apply to standard flexibles of 80 ShoreA; the article no. for alternative flexible types is available on request.

Ordering example

- N-EUPEX H coupling, size 160, S = 200 mm
- Part 1: Bore D1 60H7 mm, keyway to DIN 6885-1 and set screw
- Part 2: Bore D2 55H7 mm, keyway to DIN 6885-1 and set screw

Article no.: 2LC0100-7AG99-0AD0-Z L1E+M1D

¹⁾ To identify complete item numbers specifying the available finish boring options and – if necessary – further order options, please use our configurators on flender.com.

↗ For online configuration on flender.com, click on the item no.

TYPE D

for easy elastomer flexible replacement

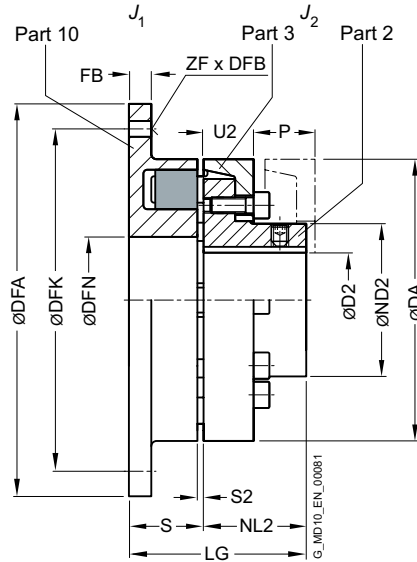

Size	Rated torque flexible type 80 ShoreA T_{KN} Nm	Speed n_{Kmax} rpm	Dimensions in mm		Flange connection dimensions											Mass moment of inertia		Article no. ¹⁾	Weight m kg	
			Bore with keyway to DIN 6885	D2	DA	ND2	NL2	S2	S	LG	DFA	DFN	DFK	FB	ZF	DFB	J_1 kgm ²			J_2 kgm ²
			min.	max.							h8	H7								
110	160	5300	-	38	110	62	40	3	30	70	144	62	128	10	6	9 M8	0.0034	0.003	2LC0100-4AD1 2LC0100-4AD2	2.7
125	240	5100	-	45	125	75	50	3	34	84	158	75	142	10	6	9 M8	0.0052	0.005	2LC0100-5AD1 2LC0100-5AD2	3.9
140	360	4900	-	50	140	82	55	3	37	92	180	82	160	13	6	11 M10	0.011	0.008	2LC0100-6AD1 2LC0100-6AD2	5.6
160	560	4250	-	58	160	95	60	4	43	103	200	95	180	13	7	11 M10	0.017	0.014	2LC0100-7AD1 2LC0100-7AD2	7.5
180	880	3800	-	65	180	108	70	4	46	116	220	110	200	13	8	11 M10	0.026	0.025	2LC0100-8AD1 2LC0100-8AD2	10.3
200	1340	3400	-	75	200	122	80	4	51	131	248	120	224	16	8	14 M12	0.051	0.04	2LC0101-0AD1 2LC0101-0AD2	14.7
225	2000	3000	-	85	225	138	90	4	56	146	274	135	250	16	8	14 M12	0.085	0.08	2LC0101-1AD1 2LC0101-1AD2	19.5
250	2800	2750	-	95	250	155	100	5.5	65.5	165.5	314	150	282	20	8	18 M16	0.16	0.13	2LC0101-2AD1 2LC0101-2AD2	28.0
280	3900	2450	54	105	280	172	110	5.5	70.5	180.5	344	170	312	20	8	18 M16	0.24	0.2	2LC0101-3AD1 2LC0101-3AD2	35.0

Configurable variants ¹⁾

- ØD2 Without finished bore
With finished bore

¹⁾ To identify complete item numbers specifying the available finish boring options and – if necessary – further order options, please use our configurators on flender.com.

↗ For online configuration on flender.com, click on the item no.

Size	Rated torque flexible type 80 ShoreA T_{KN} Nm	Speed n_{Kmax} rpm	Dimensions in mm													Mass moment of inertia		Article no. ¹⁾	Weight m kg	
			Bore with keyway to DIN 6885		Flange connection dimensions									J_1 kgm ²	J_2 kgm ²					
			D2 min.	max.	DA	ND2	NL2	S2	S	LG	DFA h8	DFN H7	DFK			FB	ZF			DFB
315	5500	2150	46	100	315	165	125	5.5	75.5	200.5	380	200	348	22	9	18	0.4	0.32	2LC0101-4AD1	47
			90	120		200														0.35
315	5500	2150	46	100	315	165	125	5.5	75.5	200.5	380	200	348	22	9	M16	0.4	0.32	2LC0101-4AD2	47
			90	120		200														0.35
350	7700	2000	61	110	350	180	140	5.5	79.5	219.5	430	225	390	25	9	22	0.7	0.54	2LC0101-5AD1	64
			90	140		230														0.61
350	7700	2000	61	110	350	180	140	5.5	79.5	219.5	430	225	390	25	9	M20	0.7	0.54	2LC0101-5AD2	64
			90	140		230														0.61
400	10300	1700	66	120	400	200	160	5.5	83.5	243.5	480	265	440	25	10	22	1.1	1.0	2LC0101-6AD1	86
			100	150		250														1.1
400	10300	1700	66	120	400	200	160	5.5	83.5	243.5	480	265	440	25	10	M20	1.1	1.0	2LC0101-6AD2	86
			100	150		250														1.1
440	13500	1550	80	130	440	215	180	7.5	93.5	273.5	520	295	480	25	10	22	1.7	1.5	2LC0101-7AD1	114
			120	160		265														1.7
440	13500	1550	80	130	440	215	180	7.5	93.5	273.5	520	295	480	25	10	M20	1.7	1.5	2LC0101-7AD2	114
			120	160		265														1.7
480	16600	1400	90	145	480	240	190	7.5	97.5	287.5	575	325	528	30	10	26	2.7	2.3	2LC0101-8AD1	146
			136	180		300														2.6
480	16600	1400	90	145	480	240	190	7.5	97.5	287.5	575	325	528	30	10	M24	2.7	2.3	2LC0101-8AD2	146
			136	180		300														2.6
520	21200	1300	100	150	520	250	210	7.5	109.5	319.5	615	355	568	30	10	26	3.8	3.3	2LC0102-0AD1	177
			140	190		315														3.7
520	21200	1300	100	150	520	250	210	7.5	109.5	319.5	615	355	568	30	10	M24	3.8	3.3	2LC0102-0AD2	177
			140	190		315														3.7

Configurable variants ¹⁾

- ØD2 Without finished bore
With finished bore

Notes

- For dimensions U2 and P, see type A on **Page 7/14**.
- The hub diameter of the component part is assigned according to the diameter of the finished bore. Where bore diameters overlap, the component with the smaller hub diameter is always selected.
- Weights and mass moments of inertia apply to maximum bore diameters.
- The article numbers apply to standard flexibles of 80 ShoreA; the article no. for alternative flexible types is available on request.

Ordering example

- N-EUPEX D coupling, size 125
- Part 10: with through bores
- Part 2: Bore D2 38H7 mm, with keyway to DIN 6885-1 and set screw

Article no.: **2LC0100-5AD19-0AA0-Z M0V**

¹⁾ To identify complete item numbers specifying the available finish boring options and – if necessary – further order options, please use our configurators on **flender.com**.

↗ For online configuration on **flender.com**, click on the item no.

TYPE E

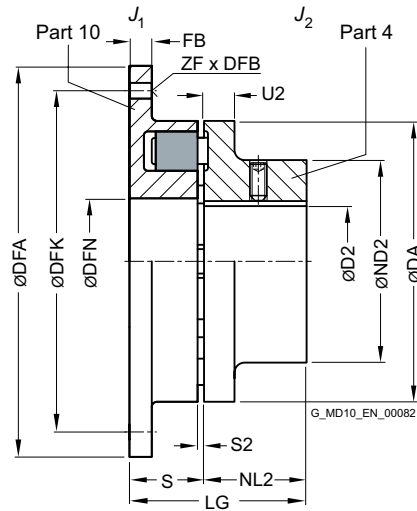

Size	Rated torque flexible type 80 ShoreA T_{KN} Nm	Speed n_{Kmax} rpm	Dimensions in mm										Mass moment of inertia		Article no. ¹⁾	Weight m kg				
			Bore with keyway to DIN 6885		Flange connection dimensions								J_1 kgm ²	J_2 kgm ²						
			D2 min.	D2 max.	DA	ND2	NL2	S2	S	LG	DFA h8	DFN H7	DFK	FB	ZF	DFB				
68	34	7000	-	28	68	50	20	3	23	43	90	34	80	7	6	$\frac{5.5}{M5}$	0.0004	0.0002	2LC0100-1AC1 2LC0100-1AC2	0.63
80	60	6000	-	38	80	68	30	3	24	54	106	42	94	8	6	$\frac{6.6}{M6}$	0.0008	0.0006	2LC0100-2AC1 2LC0100-2AC2	1.35
95	100	5500	-	42	95	76	35	3	27	62	120	52	108	8	6	$\frac{6.6}{M6}$	0.0014	0.0013	2LC0100-3AC1 2LC0100-3AC2	2.0
110	160	5300	-	48	110	86	40	3	30	70	144	62	128	10	6	$\frac{9}{M8}$	0.0034	0.0030	2LC0100-4AC1 2LC0100-4AC2	3.0
125	240	5100	-	55	125	100	50	3	34	84	158	75	142	10	6	$\frac{9}{M8}$	0.0052	0.0060	2LC0100-5AC1 2LC0100-5AC2	4.5
140	360	4900	-	60	140	100	55	3	37	92	180	82	160	13	6	$\frac{11}{M10}$	0.011	0.007	2LC0100-6AC1 2LC0100-6AC2	5.6
160	560	4250	-	65	160	108	60	4	43	103	200	95	180	13	7	$\frac{11}{M10}$	0.017	0.01	2LC0100-7AC1 2LC0100-7AC2	7.2

Configurable variants ¹⁾

- ØD2 Without finished bore
With finished bore

¹⁾ To identify complete item numbers specifying the available finish boring options and – if necessary – further order options, please use our configurators on flender.com.

↗ For online configuration on flender.com, click on the item no.

Size	Rated torque flexible type 80 ShoreA T_{KN} Nm	Speed n_{Kmax} rpm	Dimensions in mm													Mass moment of inertia		Article no. ¹⁾	Weight m kg	
			Bore with keyway to DIN 6885 D2 min. max.		DA	ND2	NL2	S2	S	LG	Flange connection dimensions						J_1 kgm ²			J_2 kgm ²
180	880	3800	-	75	180	125	70	4	46	116	220	110	200	13	8	$\frac{11}{M10}$	0.026	0.02	<u>2LC0100-8AC1</u> <u>2LC0100-8AC2</u>	10.3
200	1340	3400	-	85	200	140	80	4	51	131	248	120	224	16	8	$\frac{14}{M12}$	0.051	0.04	<u>2LC0101-0AC1</u> <u>2LC0101-0AC2</u>	14
225	2000	3000	-	90	225	150	90	4	56	146	274	135	250	16	8	$\frac{14}{M12}$	0.085	0.07	<u>2LC0101-1AC1</u> <u>2LC0101-1AC2</u>	17
250	2800	2750	46	100	250	165	100	5.5	65.5	165.5	314	150	282	20	8	$\frac{18}{M16}$	0.16	0.12	<u>2LC0101-2AC1</u> <u>2LC0101-2AC2</u>	26
280	3900	2450	54	110	280	180	110	5.5	70.5	180.5	344	170	312	20	8	$\frac{18}{M16}$	0.24	0.18	<u>2LC0101-3AC1</u> <u>2LC0101-3AC2</u>	32

Configurable variants ¹⁾

- ØD2 Without finished bore
With finished bore

Notes

- For dimension U2, see type B on **Page 7/16**.
- Weights and mass moments of inertia apply to maximum bore diameters.
- The article numbers apply to standard flexibles of 80 ShoreA; the article no. for alternative flexible types is available on request.

Ordering example

- N-EUPEX E coupling, size 125
- Part 10: with through bores
- Part 4: Bore D2 38H7 mm, with keyway to DIN 6885-1 and set screw

Article no.: **2LC0100-5AC19-0AA0-Z M0V**

¹⁾ To identify complete item numbers specifying the available finish boring options and – if necessary – further order options, please use our configurators on **flender.com**.

➤ For online configuration on **flender.com**, click on the item no.

TYPE P

with brake drum

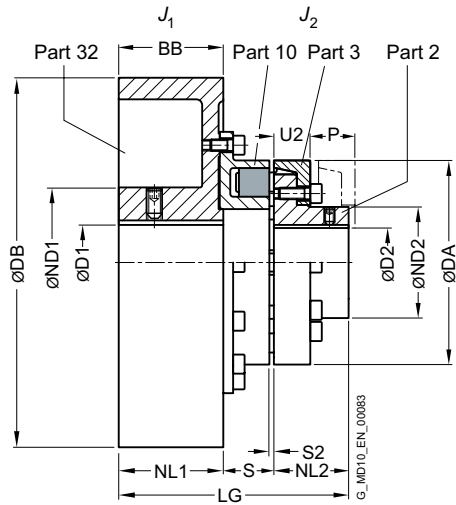

Size	Rated torque flexible type 80 ShoreA T_{KN} Nm	Speed n_{Kmax} rpm	Dimensions in mm													Mass moment of inertia		Article no. ¹⁾	Weight m kg		
			Bore with keyway to DIN 6885				DA	ND1	ND2	NL1BB	NL2	S2	S	DB	U2	LG	J_1 kgm ²			J_2	
			D1 min.	D1 max.	D2 min.	D2 max.															
125	240	4800	-	55	-	45	125	84	75	75	50	3	31	200	23	156	0.043	0.004	2LC0100-5AF	10.9	
140	360	3800	-	60	-	50	140	128	82	95	55	3	34	250	28	184	0.13	0.008	2LC0100-6AF	21	
160	560	3800	-	70	-	58	160	128	95	95	60	4	40	250	28	195	0.14	0.014	2LC0100-7AF	22	
		3000	-	80	-	65	180	128	108	118	70	4	43	315	30	206	0.16	0.025	2LC0100-8AF	28	
180	880	3000	-	80	-	65	180	128	118	118	70	4	48	315	30	231	0.35	0.025	2LC0100-8AF	35	
		3000	-	80	-	65	180	128	118	118	70	4	48	315	30	246	0.37	0.025	2LC0101-0AF	40	
		2400	-	90	-	75	200	160	122	150	80	4	48	400	32	278	1.1	0.04	2LC0101-0AF	60	
200	1340	1900	-	110	-	75	200	175	190	190	80	4	48	500	32	318	2.8	0.04	2LC0101-0AF	98	
		3000	-	80	-	65	180	128	118	118	70	4	51	315	30	259	0.39	0.08	2LC0101-1AF	47	
		2400	-	90	-	85	225	160	138	150	90	4	53	400	38	293	1.1	0.08	2LC0101-1AF	65	
225	2000	1900	38	110	-	75	200	175	190	190	80	4	53	500	38	333	3.1	0.08	2LC0101-1AF	104	
		2400	-	100	-	95	250	160	155	150	100	5.5	62.5	400	42	312.5	1.16	0.13	2LC0101-2AF	76	
		1900	38	110	-	95	250	175	155	190	100	5.5	62.5	500	42	352.5	2.9	0.13	2LC0101-2AF	113	
250	2800	2400	-	100	-	95	250	160	150	150	100	5.5	65.5	400	42	325.5	1.24	0.13	2LC0101-3AF	85	
		1900	38	110	-	95	250	175	172	190	110	5.5	67.5	500	42	367.5	3.1	0.2	2LC0101-3AF	118	
		1500	48	110	54	105	280	175	172	190	110	5.5	67.5	630	42	413.5	8.0	0.2	2LC0101-3AF	171	

Configurable variants ¹⁾

- ØD1 Without finished bore
With finished bore
- ØD2 Without finished bore
With finished bore

¹⁾ To identify complete item numbers specifying the available finish boring options and – if necessary – further order options, please use our configurators on flender.com.

↗ For online configuration on flender.com, click on the item no.

Size	Rated torque flexible type 80 ShoreA T_{KN} Nm	Speed n_{Kmax} rpm	Dimensions in mm Bore with keyway to DIN 6885														Mass moment of inertia		Article no. ¹⁾	Weight m kg
			D1 min. max.		D2 min. max.		DA	ND1	ND2	NL1BB	NL2	S2	S	DB	U2	LG	J_1 kgm ²	J_2		
315	5500	2150	-	100	46	100	315	160	150	165	125	5.5	72.5	400	347.5	1.4	0.32	2LC0101-4AF	96	
		1900	48	110				175	190				72.5	500	387.5	3.3		2LC0101-4AF	134	
		1500	48	110				175	236				72.5	630	433.5	8.2		2LC0101-4AF	183	
		1300	55	120				192	265				72.5	710	462.5	14.2		2LC0101-4AF	236	
315	5500	2150	-	100	90	120	315	160	150	200	125	5.5	72.5	400	347.5	1.4	0.35	2LC0101-4AF	97	
		1900	48	110				175	190				72.5	500	387.5	3.3		2LC0101-4AF	136	
		1500	48	110				175	236				72.5	630	433.5	8.2		2LC0101-4AF	185	
		1300	55	120				192	265				72.5	710	462.5	14.2		2LC0101-4AF	238	
350	7700	1500	48	110	61	110	350	175	236	180	140	5.5	76.5	630	452.5	8.5	0.54	2LC0101-5AF	200	
		1300	55	120				192	265				76.5	710	481.5	14.6		2LC0101-5AF	253	
350	7700	1500	48	110	90	140	350	175	236	230	140	5.5	76.5	630	452.5	8.5	0.61	2LC0101-5AF	203	
		1300	55	120				192	265				76.5	710	481.5	14.6		2LC0101-5AF	257	

Configurable variants¹⁾

- ØD1 Without finished bore
With finished bore
- ØD2 Without finished bore
With finished bore

Notes

- For dimensions U2 and P, see type A on **Page 7/14**.
- Weights and mass moments of inertia apply to maximum bore diameters.
- The article numbers apply to standard flexibles of 80 ShoreA; the article no. for alternative flexible types is available on request.

Ordering example

- N-EUPEX P coupling, size 200, brake drum 315 x 118 mm
- Part 32: Bore D1 55H7 mm, keyway to DIN 6885 P9 and set screw
- Part 4: Bore D2 60H7 mm, keyway to DIN 6885 and set screw
- Coupling micro-balanced G6.3 at 1500 rpm in accordance with half parallel key standard

Article no.: 2LC0101-0AF99-0DA0-Z L1D+M1E+W02+Y95
Plain text to Y95: G 6.3 N, n = 1500 rpm

¹⁾ To identify complete item numbers specifying the available finish boring options and – if necessary – further order options, please use our configurators on **flender.com**.

➤ For online configuration on **flender.com**, click on the item no.

TYPE O

with brake drum

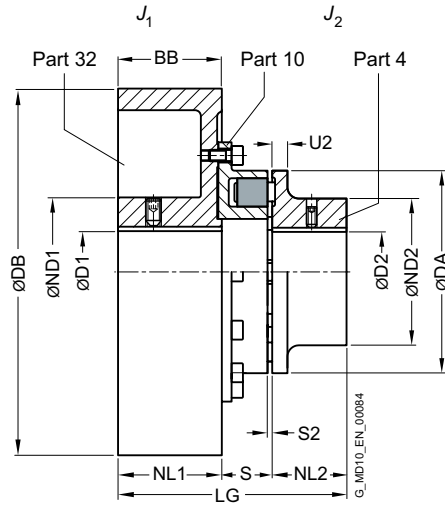

Size	Rated torque flexible type T_{KN} Nm	Speed n_{Kmax} rpm	Dimensions in mm													Mass moment of inertia		Article no. ¹⁾	Weight m kg		
			Bore with keyway to DIN 6885				DA	ND1	ND2	NL1/BB	NL2	S2	S	DB	U2	LG	J_1 kgm ²			J_2	
			D1 min.	D1 max.	D2 min.	D2 max.															
125	240	4800	-	55	-	55	125	84	100	75	50	3	31	200	18	156	0.043	0.006	2LC0100-5AE	11.3	
140	360	3800	-	60	-	60	140	128	100	95	55	3	34	250	20	184	0.13	0.007	2LC0100-6AE	22.3	
160	560	3800	-	70	-	65	160	128	108	95	60	4	40	250	20	195	0.14	0.01	2LC0100-7AE	24	
180	880	3800	-	80	-	75	180	128	125	95	70	4	41	250	20	206	0.16	0.02	2LC0100-8AE	28	
		3000	-	80	118	43				315			231	0.35		2LC0100-8AE	35				
200	1340	3000	-	80	-	85	200	128	118	150	80	4	48	315	24	246	0.37	0.04	2LC0101-0AE	40	
		2400	-	90	175	48							400	278		1.10	2LC0101-0AE		60		
		1900	-	110	190	48							500	318		2.80	2LC0101-0AE		98		

Configurable variants ¹⁾

- ØD1 Without finished bore
With finished bore
- ØD2 Without finished bore
With finished bore

¹⁾ To identify complete item numbers specifying the available finish boring options and – if necessary – further order options, please use our configurators on flender.com.

↗ For online configuration on flender.com, click on the item no.

Size	Rated torque flexible type 80 ShoreA T_{KN} Nm	Speed n_{Kmax} rpm	Dimensions in mm													Mass moment of inertia		Article no. ¹⁾	Weight m kg		
			Bore with keyway to DIN 6885		D1 min.	D1 max.	D2 min.	D2 max.	DA	ND1	ND2	NL1/BB	NL2	S2	S	DB	U2			LG	J_1 kgm ²
225	2000	3000	-	80																	
		2400	-	90	-	90	225	160	150					53	400	293	1.10			2LC0101-1AE	63
		1900	38	110				175	190					53	500	333	3.10			2LC0101-1AE	102
250	2800	2400	-	100	46	100	250	160	165	150	100	5.5	62.5	400	18	312.5	1.16	0.12		2LC0101-2AE	73
		1900	38	110				175	190	190				62.5	500		352.5	2.90		2LC0101-2AE	108
280	3900	2400	-	100				160		150				65.5	400		325.5	1.24		2LC0101-3AE	82
		1900	48	110	54	110	280	175	180	190	110	5.5	67.5	500	20	367.5	3.10	0.18		2LC0101-3AE	115
		1500	48	110				175		236				67.5	630		413.5	8.0		2LC0101-3AE	168

Configurable variants ¹⁾

- ØD1 Without finished bore
With finished bore
- ØD2 Without finished bore
With finished bore

Notes

- Weights and mass moments of inertia apply to maximum bore diameters.
- The article numbers apply to standard flexibles of 80 ShoreA; the article no. for alternative flexible types is available on request.

Ordering example

- N-EUPEX O coupling, size 200, brake drum 315 x 118 mm
- Part 32: Bore D1 55H7 mm, keyway to DIN 6885 P9 and set screw
- Part 4: Bore D2 60H7 mm, keyway to DIN 6885 and set screw
- Coupling micro-balanced G6.3 at 1500 rpm in accordance with half parallel key standard

Article no.: 2LC0101-0AE99-0DA0-Z L1D+M1E+W02+Y95
Plain text to Y95: G 6.3 N, n = 1500 rpm

¹⁾ To identify complete item numbers specifying the available finish boring options and – if necessary – further order options, please use our configurators on flender.com.

➤ For online configuration on flender.com, click on the item no.

TYPE DBDR

with brake disk

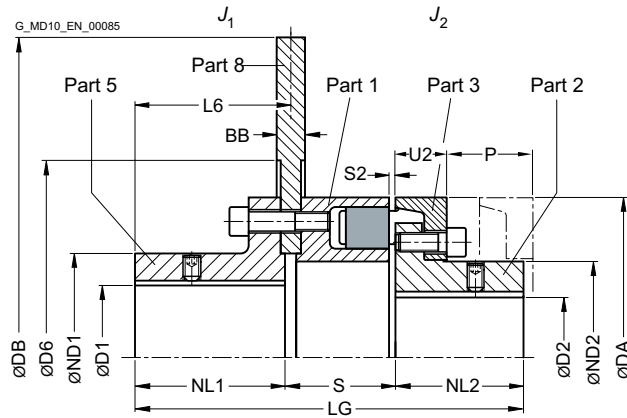

Size	Rated torque flexible type 80 ShoreA T_{KN} Nm	Dimensions in mm														Mass moment of inertia		Article no. ¹⁾	Weight m kg
		Bore with key-way to DIN 6885			DA	ND1	ND2	NL1	NL2	S ²⁾	S ²⁾	DB ³⁾ min.	D ₆ min.	BB ³⁾	L ₆	L _G	J_1 min. kgm ²		
D1 max.	D2 min.	D2 max.																	
140	360	55	-	50	140	85	82	72	54.35	3	315	150	12.7	74	181.35	0.11	0.008	2LC0100-6AV	15.5
								72	57.5				30	200	316	0.24			17
								188	73				30	200	316	0.24			28.5
160	560	70	-	58	160	105	95	90	58.35	4	315	170	12.7	91	208.35	0.12	0.014	2LC0100-7AV	19
								90	62.5				30	200	326	0.26			20.5
								188	78				30	200	326	0.26			32
180	880	80	-	65	180	125	108	90	60.35	4	315	190	12.7	91	220.35	0.29	0.025	2LC0100-8AV	23
								90	64.5				30	200	338	0.43			24.5
								188	80				30	200	338	0.43			38
200	1340	90	-	75	200	135	122	95	67.35	4	355	210	12.7	97	242.35	0.22	0.04	2LC0101-0AV	31
								95	70.5				15	99	245.5	0.25			32
								188	86				30	200	354	0.45			48
225	2000	105	-	85	225	160	138	100	72.35	4	400	235	12.7	103	262.35	0.37	0.08	2LC0101-1AV	41
								100	74.5				15	104	264.5	0.42			43
								188	90				30	200	368	0.74			64
250	2800	110	-	95	250	170	155	105	83.35	6	450	260	12.7	107	288.35	1.4	0.13	2LC0101-2AV	54
								105	86.5				15	109	291.5	1.5			57
								188	102				30	200	390	2.0			81

Configurable variants ¹⁾

- ØD1 Without finished bore
With finished bore
- ØD2 Without finished bore
With finished bore

¹⁾ To identify complete item numbers specifying the available finish boring options and – if necessary – further order options, please use our configurators on flender.com.

²⁾ The ΔS clearance for coupling sizes 250, 280, 315 and 350 is +2/-3 mm.

³⁾ For the available DB · BB brake disk dimensions, please refer to the product configurator on flender.com.

➤ For online configuration on flender.com, click on the item no.

Size	Rated torque flexible type 80 ShoreA T_{KN} Nm	Dimensions in mm															Mass moment of inertia		Article no. ¹⁾	Weight m kg
		Bore with keyway to DIN 6885			DA	ND1	ND2	NL1	NL2	S ²⁾	S2 ²⁾	DB ³⁾ min.	D6 min.	BB ³⁾	L6	LG	J_1 min. kgm ²	J_2 kgm ²		
280	3900	130	54	105	280	200	172	120	110	90.5	6	500	350	12.7	122	317.35	0.94	0.20	2LC0101-3AV	71
					188	106	15	124	320.5	1.0	74									
					30	200	404	1.8	105											
315	5500	130	46	100	315	200	165	130	125	92.5	6	500	350	12.7	130	342.35	1.1	0.32	2LC0101-4AV	86
					188	108	15	134	347.5	1.2	89									
					30	200	421	2.0	115											
			90	120	315	200	200	130	125	92.5	6	500	350	15	134	347.5	1.2	0.35	2LC0101-4AV	92
					188	108	30	200	421	2.0	120									
					135	97.35	12.7	136	372.35	1.5	110									
350	7700	140	61	110	350	230	180	135	140	101.5	6	500	360	12.7	136	372.35	1.5	0.54	2LC0101-5AV	115
					188	117	15	139	376.5	1.6	115									
					30	200	445	2.3	140											
			90	140	350	230	230	135	140	101.5	6	500	360	12.7	136	372.35	1.5	0.61	2LC0101-5AV	115
					188	117	15	139	376.5	1.6	115									
					30	200	445	2.3	145											

Configurable variants¹⁾

- ØD1 Without finished bore
With finished bore
- ØD2 Without finished bore
With finished bore

Notes

- For dimensions U2 and P, see type A on Page 7/14.
- Weights and mass moments of inertia apply to maximum bore diameters.
- Maximum speed in rpm: $n_{max} = 1146/DB$ DB in m
- Other brake disk diameters DB and brake disk widths BB on request.
- The article numbers apply to standard flexibles of 80 ShoreA; the article no. for alternative flexible types is available on request.

Ordering example

- N-EUPEX DBDR coupling, size 200, brake disk 450 x 30 mm
- Part 5: Bore D1 55H7 mm, keyway to DIN 6885 P9 and set screw
- Part 2: Bore D2 60H7 mm, keyway to DIN 6885 and set screw
- Coupling micro-balanced G6.3 at 1500 rpm in accordance with half parallel key standard

Article no.: 2LC0101-0AV99-0G A0-Z L1D+M1E+W02+Y95
Plain text to Y95: G 6.3 N, n = 1500 rpm

¹⁾ To identify complete item numbers specifying the available finish boring options and – if necessary – further order options, please use our configurators on flieder.com.
²⁾ The ΔS clearance for coupling sizes 250, 280, 315 and 350 is +2/-3 mm.

³⁾ For the available DB·BB brake disk dimensions, please refer to the product configurator on flieder.com.
➤ For online configuration on flieder.com, click on the item no.

TYPE DBD

with brake disk

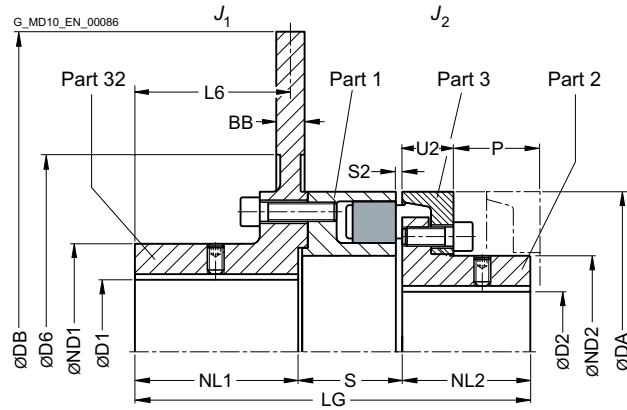

Size	Rated torque flexible type 80 ShoreA T_{KN} Nm	Dimensions in mm														Mass moment of inertia		Article no. ¹⁾	Weight m kg		
		Bore with keyway to DIN 6885			DA	ND1	ND2	NL1	NL2	S ²⁾	S2 ²⁾	DB ³⁾	D6	BB ³⁾	L6	LG	J_1			J_2	
		D1 max.	D2 min.	D2 max.																	
140	360	55	-	50	140	85	82	81.5	55	49.5	3	315	150	12.7	74	186	0.10	0.008	2LC0100-6AU	15	
								81.5						15	73	186	0.12			16	
								211.5						30	200	316	0.22			26	
160	560	70	-	58	160	105	95	98.5	60	54.5	4	315	170	12.7	91	213	0.11	0.014	2LC0100-7AU	18	
								98.5						15	90	213	0.13			19	
								211.5						30	200	326	0.23			30	
180	880	80	-	65	180	125	108	98.5	70	56.5	4	315	190	12.7	91	225	0.28	0.025	2LC0100-8AU	22	
								98.5						15	90	225	0.29			23	
								211.5						30	200	338	0.40			35	
200	1340	90	-	75	200	135	122	104.5	80	62.5	4	355	210	12.7	97	247	0.21	0.04	2LC0101-0AU	30	
								104.5						15	96	247	0.23			31	
								211.5						30	200	354	0.41			45	
225	2000	105	-	85	225	160	138	111.5	90	66.5	4	400	235	12.7	103	268	0.35	0.08	2LC0101-1AU	39	
								111.5						15	102	268	0.38			41	
								211.5						30	200	368	0.67			59	
250	2800	110	-	95	250	170	155	116.5	100	78.5	6	450	260	12.7	107	295	1.4	0.13	2LC0101-2AU	52	
								116.5						15	106	295	1.4			54	
								211.5						30	200	390	1.9			75	

Configurable variants ¹⁾

- ØD1 Without finished bore
With finished bore
- ØD2 Without finished bore
With finished bore

¹⁾ To identify complete item numbers specifying the available finish boring options and – if necessary – further order options, please use our configurators on flender.com.

²⁾ The ΔS clearance for coupling sizes 250, 280, 315 and 350 is +2/-3 mm.

³⁾ For the available DB · BB brake disk dimensions, please refer to the product configurator on flender.com.

➤ For online configuration on flender.com, click on the item no.

Size	Rated torque flexible type 80 ShoreA T_{KN} Nm	Dimensions in mm														Mass moment of inertia		Article no. ¹⁾	Weight m kg						
		Bore with keyway to DIN 6885			DA	ND1	ND2	NL1	NL2	S ²⁾	S ²⁾	DB ³⁾	D6	BB ³⁾	L6	LG	J_1 min. kgm ²			J_2 kgm ²					
		D1 max.	D2 min.	max.																					
280	3900	130	54	105	280	200	172	131.5	110	82.5	6	500	350	12.7	122	324	0.87	0.20	2LC0101-3AU	68					
								131.5						15	121	324	0.96			71					
								211.5						30	200	404	1.6			96					
315	5500	130	46	100	315	200	165	141.5	125	84.5	6	500	350	12.7	130	351	1.0	0.32	2LC0101-4AU	82					
								141.5						15	129	351	1.1			84					
								211.5						30	200	421	1.7			105					
			90	120	315	200	200	141.5	125	84.5	6	500	350	12.7	130	351	1.0	0.35	2LC0101-4AU	85					
																				141.5	15	129	351	1.1	87
																				211.5	30	200	421	1.7	110
350	7700	140	61	110	350	220	180	146.5	140	93.5	6	500	360	12.7	135	380	2.1	0.54	2LC0101-5AU	125					
								146.5						15	134	380	2.2			125					
								211.5						30	200	445	2.0			125					
			90	140	350	220	230	146.5	140	93.5	6	500	360	12.7	135	380	2.1	0.61	2LC0101-5AU	125					
																				146.5	15	134	380	2.2	130
																				211.5	30	200	445	2.0	130

Configurable variants¹⁾

- ØD1 Without finished bore
With finished bore
- ØD2 Without finished bore
With finished bore

Notes

- For dimensions U2 and P, see type A on Page 7/14.
- Weights and mass moments of inertia apply to maximum bore diameters.
- Maximum speed in rpm: $n_{max} = 1146/DB$ DB in m
- Other brake disk diameters DB and brake disk widths BB on request.
- The article numbers apply to standard flexibles of 80 ShoreA; the article no. for alternative flexible types is available on request.

Ordering example

- N-EUPEX DBD coupling, size 200, brake disk 450 x 30 mm
- Part 32: Bore D1 55H7 mm, keyway to DIN 6885 P9 and set screw
- Part 2: Bore D2 60H7 mm, keyway to DIN 6885 and set screw
- Coupling micro-balanced G6.3 at 1500 rpm in accordance with half parallel key standard

Article no.: 2LC0101-0AU99-0GA0-Z L1D+M1E+W02+Y95
Plain text to Y95: G 6.3 N, n = 1500 rpm

¹⁾ To identify complete item numbers specifying the available finish boring options and – if necessary – further order options, please use our configurators on flender.com.
²⁾ The ΔS clearance for coupling sizes 250, 280, 315 and 350 is +2/-3 mm.

³⁾ For the available DB · BB brake disk dimensions, please refer to the product configurator on flender.com.
↗ For online configuration on flender.com, click on the item no.

TYPE EBD

with brake disk

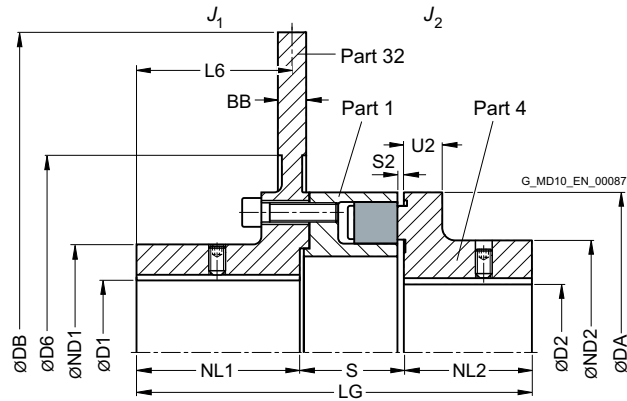

7

Size	Rated torque flexible type 80 ShoreA T_{KN} Nm	Dimensions in mm Bore with keyway to DIN 6885														Mass moment of inertia		Article no. ¹⁾	Weight m kg	
		D1 max.	D2 min.	D2 max.	DA	ND1	ND2	NL1	NL2	S ²⁾	S2 ²⁾	DB ³⁾ min.	D6 min.	BB ³⁾	L6	LG	J_1 min. kgm ²			J_2 kgm ²
140	360	55	-	60	140	85	100	81.5	55	49.5	3	315	150	12.7	74	186	0.10	0.007	2LC0100-6AW	15
								211.5						30	200	316	0.22			16
								98.5						15	90	213	0.11			18
160	560	70	-	65	160	105	108	98.5	60	54.5	4	315	170	12.7	91	213	0.11	0.01	2LC0100-7AW	19
								211.5						30	200	326	0.23			26
								98.5						15	90	213	0.13			18
180	880	80	-	75	180	125	125	98.5	70	56.5	4	315	190	12.7	91	225	0.28	0.02	2LC0100-8AW	22
								211.5						30	200	338	0.40			23
								104.5						15	90	225	0.29			25
200	1340	90	-	85	200	135	140	104.5	80	62.5	4	355	210	12.7	97	247	0.21	0.04	2LC0101-0AW	30
								211.5						30	200	354	0.41			31
								104.5						15	96	247	0.23			31

Configurable variants ¹⁾

- ØD1 Without finished bore
With finished bore
- ØD2 Without finished bore
With finished bore

¹⁾ To identify complete item numbers specifying the available finish boring options and – if necessary – further order options, please use our configurators on flender.com.

²⁾ The ΔS clearance for coupling sizes 250, 280, 315 and 350 is +2/-3 mm.

³⁾ For the available DB · BB brake disk dimensions, please refer to the product configurator on flender.com.

➤ For online configuration on flender.com, click on the item no.

Size	Rated torque flexible type 80 ShoreA T_{KN} Nm	Dimensions in mm Bore with keyway to DIN 6885														Mass moment of inertia		Article no. ¹⁾	Weight m kg			
		D1 max.	D2 min.	max.	DA	ND1	ND2	NL1	NL2	S ²⁾	S2 ²⁾	DB ³⁾ min.	D6 min.	BB ³⁾	L6	LG	J_1 min. kgm ²			J_2 kgm ²		
225	2000	105	-	90	225	160	150	111.5	90	66.5	4	400	235	12.7	103	268	0.35	2LC0101-1AW	39			
					111.5	90	66.5	4						400	235	15	102		268	0.38	0.07	41
					211.5											30	200		368	0.67		
250	2800	110	46	100	250	170	165	116.5	100	78.5	6	450	260	12.7	107	295	1.4	2LC0101-2AW	52			
					116.5	100	78.5	6						450	260	15	106		295	1.4	0.12	54
					211.5											30	200		390	1.9		
280	3900	130	54	110	280	200	180	131.5	110	82.5	6	500	350	12.7	122	324	0.87	2LC0101-3AW	68			
					131.5	110	82.5	6						500	350	15	121		324	0.96	0.18	71
					211.5											30	200		404	1.6		

Configurable variants ¹⁾

- ØD1 Without finished bore
With finished bore
- ØD2 Without finished bore
With finished bore

Notes

- For dimension U2, see type B on Page 7/16.
- Weights and mass moments of inertia apply to maximum bore diameters.
- Maximum speed in rpm: $n_{max} = 1146/DB$ DB in m
- Other brake disk diameters DB and brake disk widths BB on request.
- The article numbers apply to standard flexibles of 80 ShoreA; the article no. for alternative flexible types is available on request.

Ordering example

- N-EUPEX EBD coupling, size 200, brake disk 450 x 30 mm
- Part 32: Bore D1 55H7 mm, keyway to DIN 6885 P9 and set screw
- Part 4: Bore D2 60H7 mm, keyway to DIN 6885 and set screw
- Coupling micro-balanced G6.3 at 1500 rpm in accordance with half parallel key standard

Article no.: 2LC0101-0AW99-0GA0-Z L1D+M1E+W02+Y95
Plain text to Y95: G 6.3 N, n = 1500 rpm

¹⁾ To identify complete item numbers specifying the available finish boring options and – if necessary – further order options, please use our configurators on flender.com.
²⁾ The ΔS clearance for coupling sizes 250, 280, 315 and 350 is +2/-3 mm.

³⁾ For the available DB · BB brake disk dimensions, please refer to the product configurator on flender.com.
↗ For online configuration on flender.com, click on the item no.

TYPE ADS

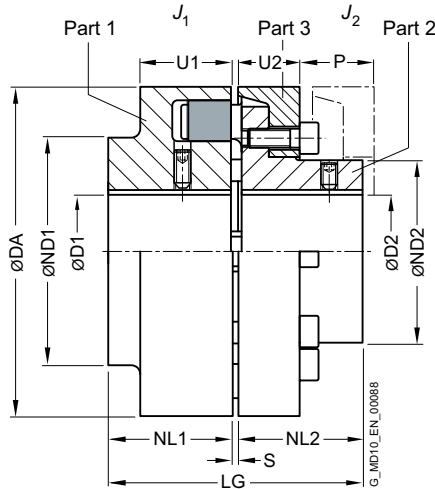

Size	Rated torque T_{KN} Nm	Speed n_{Kmax} rpm	Dimensions in mm Bore with keyway to DIN 6885													Mass moment of inertia J_1/J_2 kgm ²	Article no. ¹⁾	Weight m kg
			D1		D2		DA	ND1	ND2	NL1/ NL2	S	U1	U2	P	LG			
			min.	max.	min.	max.												
118	160	5300	-	48	-	38	118	86	62	40	3	34	20	33	83	0.003	2LC0110-4AB	3.5
135	240	5100	-	55	-	45	135	100	75	50	3	36	23	38	103	0.006	2LC0110-5AB	5.5
152	360	4900	-	60	-	50	152	108	82	55	3	36	28	43	113	0.011	2LC0110-6AB	7.7
172	560	4250	-	65	-	58	172	118	95	60	4	41	28	47	124	0.019	2LC0110-7AB	10.5
194	880	3800	-	75	-	65	194	135	108	70	4	44	30	50	144	0.036	2LC0110-8AB	15
218	1340	3400	-	85	-	75	218	150	122	80	4	47	32	53	164	0.062	2LC0111-0AB	21
245	2000	3000	-	90	-	85	245	150	138	90	4	52	38	61	184	0.10	2LC0111-1AB	28
272	2800	2750	46	100	-	95	272	165	155	100	5.5	60	42	69	205.5	0.18	2LC0111-2AB	40
305	3900	2450	49	110	54	105	305	180	172	110	5.5	65	42	73	225.5	0.28	2LC0111-3AB	50
340	5500	2150	49	120	46	100	340	200	165	125	5.5	70	47	78	255.5	0.45	2LC0111-4AB	72
380	7700	2000	61	140	61	110	380	230	180	140	5.5	74	51	83	285.5	0.75	2LC0111-5AB	100
					90	140			230							0.80		104
430	10300	1700	66	150	66	120	430	250	200	160	5.5	78	56	88	325.5	1.2	2LC0111-6AB	135
					100	150			250							1.4		140
472	13500	1550	80	160	80	130	472	265	215	180	7.5	86	64	99	367.5	2.0	2LC0111-7AB	174
					120	160			265							2.1		180
514	16600	1400	90	180	90	145	514	300	240	190	7.5	90	65	104	387.5	2.9	2LC0111-8AB	220
					136	180			300							3.2		237
556	21200	1300	100	190	100	150	556	315	250	210	7.5	102	68	115	427.5	4.3	2LC0112-0AB	281
					140	190			315							4.7		290

Configurable variants ¹⁾

- ØD1 Without finished bore
With finished bore
- ØD2 Without finished bore
With finished bore

Notes

- The hub diameter of the component part is assigned according to the diameter of the finished bore. Where bore diameters overlap, the component with the smaller hub diameter is always selected.
- Weights and mass moments of inertia apply to maximum bore diameters.

Ordering example

- N-EUPEX ADS coupling, size 135
- Part 1: Bore D1 42H7 mm, keyway to DIN 6885 and set screw
- Part 2: Bore D2 32H7 mm, keyway to DIN 6885 and set screw

Article no.: 2LC0110-5AB99-0AA0-Z L0X+M0T

¹⁾ To identify complete item numbers specifying the available finish boring options and – if necessary – further order options, please use our configurators on flender.com.

↗ For online configuration on flender.com, click on the item no.

TYPE BDS

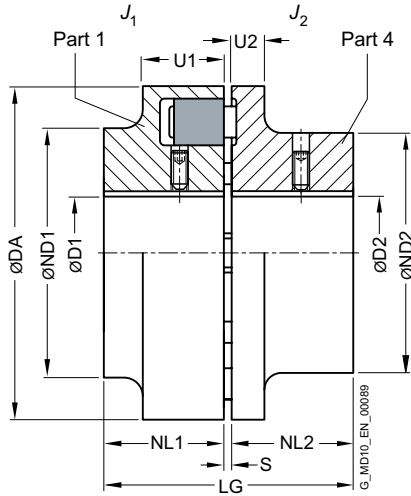

7

Size	Rated torque T_{KN} Nm	Speed n_{Kmax} rpm	Dimensions in mm											Mass moment of inertia J_1/J_2 kgm ²	Article no. ¹⁾	Weight m kg	
			Bore with keyway to DIN 6885				DA	ND1	ND2	NL1/ NL2	S	U1	U2				LG
			D1		D2												
min.	max.	min.	max.														
66	19	7500	-	19	-	24	66	66	40	20	3	20	8	43	0.0001	2LC0110-0AA	0.50
76	34	7000	-	24	-	28	76	76	50	20	3	20	8	43	0.0002	2LC0110-1AA	0.65
88	60	6000	-	30	-	38	88	88	68	30	3	30	10	63	0.0006	2LC0110-2AA	1.8
103	100	5500	-	42	-	42	103	76	76	35	3	30	12	73	0.0015	2LC0110-3AA	3
118	160	5300	-	48	-	48	118	86	86	40	3	34	14	83	0.003	2LC0110-4AA	3.7
135	240	5100	-	55	-	55	135	100	100	50	3	36	18	103	0.007	2LC0110-5AA	6.1
152	360	4900	-	60	-	60	152	108	100	55	3	36	20	113	0.011	2LC0110-6AA	7.0
172	560	4250	-	65	-	65	172	118	108	60	4	41	20	124	0.019	2LC0110-7AA	11
194	880	3800	-	75	-	75	194	135	125	70	4	44	20	144	0.035	2LC0110-8AA	17
218	1340	3400	-	85	-	85	218	150	140	80	4	47	24	164	0.06	2LC0111-0AA	23
245	2000	3000	-	90	-	90	245	150	150	90	4	52	18	184	0.085	2LC0111-1AA	27
272	2800	2750	46	100	46	100	272	165	165	100	5.5	60	18	205.5	0.15	2LC0111-2AA	36
305	3900	2450	49	110	54	110	305	180	180	110	5.5	65	20	225.5	0.25	2LC0111-3AA	47

Configurable variants ¹⁾

- ØD1 Without finished bore
With finished bore
- ØD2 Without finished bore
With finished bore

Notes

- Weights and mass moments of inertia apply to maximum bore diameters.

Ordering example

- N-EUPEX BDS coupling, size 103
- Part 1: Bore D1 42H7 mm, keyway to DIN 6885 and set screw
- Part 4: Bore D2 32H7 mm, keyway to DIN 6885 and set screw

Article no.: 2LC0110-3AA99-0AA0-Z L0X+M0T

¹⁾ To identify complete item numbers specifying the available finish boring options and – if necessary – further order options, please use our configurators on flender.com.

↗ For online configuration on flender.com, click on the item no.

TYPE HDS

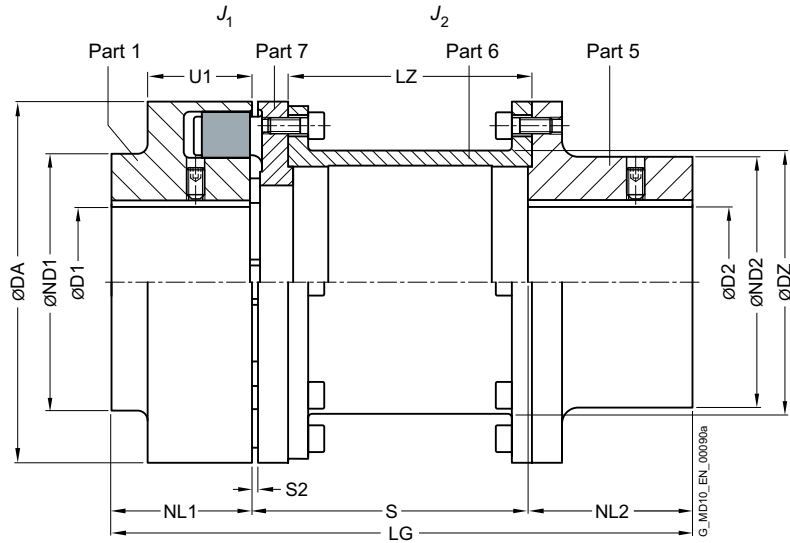

Size	Rated torque T_{KN} Nm	Speed n_{Kmax} rpm	Dimensions in mm													Mass moment of inertia		Article no. ¹⁾	Weight m kg		
			Bore with keyway to DIN 6885						DA	ND1	ND2	NL1	NL2	S2	S	LZ	DZ			LG	J_1 kgm ²
			D1 min.	D1 max.	D2 min.	D2 max.															
88	60	6000	-	30	-	32	88	88	55	30	45	5	100	87	175	0.0007	0.0014	2LC0110-2AC	2.8		
													140	127	215		0.0015				
103	100	5500	-	42	-	42	103	76	70	35	45	5	100	87	180	0.001	0.003	2LC0110-3AC	4.0		
													140	127	220		0.0033				
118	160	5300	-	48	-	48	118	86	80	40	50	5	100	85	190	0.003	0.006	2LC0110-4AC	5.3		
													50	85	230		0.0064				
													60	165	280		0.0068				
135	240	5100	-	55	-	55	135	100	90	50	60	5	100	85	200	0.006	0.01	2LC0110-5AC	7.6		
													50	125	240		0.01				
													140	125	240		0.01				
													180	165	290		0.012				
													70	185	320		0.012				
152	360	4900	-	60	-	60	152	108	100	55	65	5	180	162	91	0.011	0.02	2LC0110-6AC	11.2		
													65	140	122		0.02				
													65	140	122		0.02				
													200	182	320		0.023				
													80	232	385		0.024				
172	560	4250	-	65	-	65	172	118	108	60	70	6	180	161.5	111	0.019	0.03	2LC0110-7AC	14.3		
													70	140	121.5		0.034				
													70	140	121.5		0.034				
													200	181.5	330		0.037				
													80	231.5	390		0.039				

Configurable variants ¹⁾

- ØD1 Without finished bore
With finished bore
- ØD2 Without finished bore
With finished bore

¹⁾ To identify complete item numbers specifying the available finish boring options and – if necessary – further order options, please use our configurators on flender.com.

↗ For online configuration on flender.com, click on the item no.

Size	Rated torque T_{KN} Nm	Speed n_{Kmax} rpm	Dimensions in mm													Mass moment of inertia		Article no. ¹⁾	Weight m kg	
			Bore with keyway to DIN 6885				DA	ND1	ND2	NL1	NL2	S2	S	LZ	DZ	LG	J_1 kgm ²			J_2 kgm ²
D1	D2	min.	max.	min.	max.															
194	880	3800	-	75	-	75	194	135	125	70	80	6	140	121.5	290	0.037	0.058	2LC0110-8AC	21	
													180	161.5	330		0.062		22	
													200	181.5	350		0.064		23	
													250	231.5	400		0.069		24	
218	1340	3400	-	85	-	85	218	150	140	80	90	6	140	118.5	310	0.062	0.10	2LC0111-0AC	30	
													180	158.5	350		0.11		31	
													200	178.5	370		0.11		32	
													250	228.5	420		0.12		33	
245	2000	3000	-	90	-	90	245	150	150	90	100	6	140	118.5	330	0.09	0.16	2LC0111-1AC	35	
													180	158.5	370		0.17		36	
													200	178.5	390		0.18		37	
													250	228.5	430		0.19		39	
272	2800	2750	46	100	46	100	272	165	165	100	110	8	180	152.5	390	0.16	0.3	2LC0111-2AC	51	
													200	172.5	410		0.31		52	
													250	222.5	460		0.33		55	
													305	3900	2450		49		110	51
340	5500	2150	49	120	51	120	340	200	200	125	140	8	250	222.5	250	515	0.50	0.87	2LC0111-4AC	105
380	7700	2000	61	140	51	140	380	230	230	140	150	8	250	220.5	272	540	0.80	1.4	2LC0111-5AC	130
430	10300	1700	66	150	51	150	430	250	250	160	180	8	250	185.5	310	590	1.4	2.5	2LC0111-6AC	205
472	13500	1550	80	160	51	160	472	265	265	180	180	10	250	182	354	610	2.1	4.1	2LC0111-7AC	235

Configurable variants ¹⁾

- ØD1 Without finished bore
With finished bore
- ØD2 Without finished bore
With finished bore

Notes

- For dimension U1, see type A on Page 7/14.
- During assembly, the gap dimension S2 must not exceed the permissible tolerance of +1 mm.
- For sizes 305 to 472 the outer diameter of part 5 and part 7 is smaller than ØDA.
- Weights and mass moments of inertia apply to maximum bore diameters.

Ordering example

- N-EUPEX HDS coupling, size 103, S3 = 100 mm
- Part 1: Bore D1 42H7 mm, keyway to DIN 6885-1 and set screw
- Part 5: Bore D2 32H7 mm, keyway to DIN 6885-1 and set screw
- Coupling micro-balanced G6.3 at 1500 rpm in accordance with half parallel key standard

Article no.: 2LC0110-3AC99-0AA0-ZL0X+M0T+W02

¹⁾ To identify complete item numbers specifying the available finish boring options and – if necessary – further order options, please use our configurators on flender.com.

↗ For online configuration on flender.com, click on the item no.

SPARE AND WEAR PARTS

Elastomer flexibles of the N-EUPEX series

NBR elastomer flexibles 80 ShoreA standard type			
Size	Article No. (flexible set for one coupling)	Number of flexibles per set	Weight per set kg
58	2LC0100-0WA00-0AA0	4	0.012
68	2LC0100-1WA00-0AA0	5	0.015
80	2LC0100-2WA00-0AA0	6	0.02
95	2LC0100-3WA00-0AA0	6	0.03
110	2LC0100-4WA00-0AA0	6	0.045
125	2LC0100-5WA00-0AA0	6	0.06
140	2LC0100-6WA00-0AA0	6	0.09
160	2LC0100-7WA00-0AA0	7	0.12
180	2LC0100-8WA00-0AA0	8	0.17
200	2LC0101-0WA00-0AA0	8	0.23
225	2LC0101-1WA00-0AA0	8	0.3
250	2LC0101-2WA00-0AA0	8	0.38
280	2LC0101-3WA00-0AA0	8	0.55
315	2LC0101-4WA00-0AA0	9	0.7
350	2LC0101-5WA00-0AA0	9	0.85
400	2LC0101-6WA00-0AA0	10	1.2
440	2LC0101-7WA00-0AA0	10	1.5
480	2LC0101-8WA00-0AA0	10	2.1
520	2LC0102-0WA00-0AA0	10	2.6
560	2LC0102-1WA00-0AA0	10	3.6
610	2LC0102-2WA00-0AA0	10	4.9
660	2LC0102-3WA00-0AA0	10	6.3
710	2LC0102-4WA00-0AA0	10	7.6

Notes

- The elastomer flexibles are wear parts.
The service life depends on the operating conditions.

Elastomer flexibles of the N-EUPEX DS series

NBR elastomer flexibles standard type			
Size	Article No. (flexible set for one coupling)	Number of flexibles per set	Weight per set kg
66	2LC0110-0WA00-0AA0	4	0.012
76	2LC0110-1WA00-0AA0	5	0.015
88	2LC0110-2WA00-0AA0	6	0.021
103	2LC0110-3WA00-0AA0	6	0.033
118	2LC0110-4WA00-0AA0	6	0.048
135	2LC0110-5WA00-0AA0	6	0.072
152	2LC0110-6WA00-0AA0	6	0.1
172	2LC0110-7WA00-0AA0	7	0.16
194	2LC0110-8WA00-0AA0	8	0.21
218	2LC0111-0WA00-0AA0	8	0.28
245	2LC0111-1WA00-0AA0	8	0.45
272	2LC0111-2WA00-0AA0	8	0.64
305	2LC0111-3WA00-0AA0	8	0.72
340	2LC0111-4WA00-0AA0	9	0.92
380	2LC0111-5WA00-0AA0	9	1.2
430	2LC0111-6WA00-0AA0	10	1.6
472	2LC0111-7WA00-0AA0	10	2.0
514	2LC0111-8WA00-0AA0	10	2.5
556	2LC0112-0WA00-0AA0	10	3.2

Notes

- The elastomer flexibles are wear parts.
The service life depends on the operating conditions.

FLEXIBLE COUPLINGS RUPEX SERIES

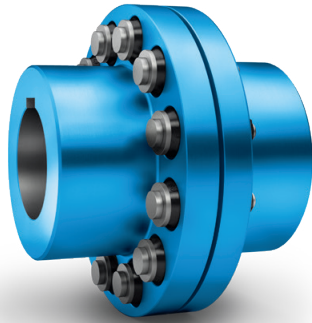

General	8/3
Benefits	8/3
Application	8/3
Design and configurations	8/4
Function	8/6
Technical specifications	8/6
<hr/>	
Type RWN – Hub material grey cast iron	8/8
<hr/>	
Type RWS – Hub material steel	8/10
<hr/>	
Type RFN – Hub material grey cast iron	8/12
<hr/>	
Type RFS – Hub material steel	8/14
<hr/>	
Type RWB – with brake disk to DIN 15432	8/16
<hr/>	
Type RBS – with brake disk to DIN 15432	8/18
<hr/>	
Type RBS – with brake disk to DIN 15432	8/20
<hr/>	
Type RWB – with brake drum to DIN 15431	8/22
<hr/>	
Type RBS – with brake drum to DIN 15431	8/23
<hr/>	
Spare and wear parts	8/24
<hr/>	



RUPEX

FLENDER

GENERAL

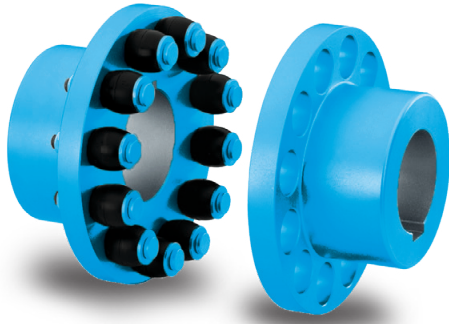

RUPEX pin and bush couplings link machine shafts and compensate for shaft misalignment with weak restorative forces. The torque is conducted through elastomer buffers, so the coupling has typically flexible rubber properties.

Benefits

RUPEX couplings can also hold loads when overloaded and are therefore especially suitable for drives for special safety and reliability requirements.

Torque shock loads and changing loads are no problem for robust, compact flexible RUPEX couplings.

The steel variant is also especially suitable for high-speed drives.

Application

RUPEX couplings are available as a catalog standard in 26 sizes with a rated torque of between 200 Nm and 1300000 Nm.

The coupling is suitable for use at ambient temperatures of between -30 °C and +80 °C. By using alternative elastomer buffers, the permissible ambient temperature range can be extended to between -50 °C and +100 °C.



Coupling suitable for use in potentially explosive atmospheres.

Complies with the current ATEX Directive for:

CE  II 2G Ex h IIC T6 ... T4 Gb X

 II 2D Ex h IIIC T85 °C ... 110 °C Db X

 I M2 Ex h Mb X

Thanks to their robust design, RUPEX couplings are also suitable for rough operating conditions.

RUPEX couplings are fitted by putting together the coupling halves. Fitting with low torsional backlash is simplified by the barrel-shaped geometry of the buffers.

RUPEX couplings require little maintenance. Only the elastomer buffers, as wear parts, need be replaced and the coupled machines need not be moved to do so.

RUPEX couplings are suitable for reversing operation and horizontal and vertical fitting or fitting at any required angle.

Frequently, the coupling is used to connect the gear shaft to the driven machine. In the case of drives without gear units, the coupling is particularly suitable for operation in rough conditions or heavy-duty drives with electric motor drive. Ventilator drives with high ventilator mass and drives in the cement industry are typical applications.

Examples of particularly safety-relevant areas of application are cable railway drives, lifting gear for crane drives or escalator drives.

GENERAL

Design and configurations

A RUPEX coupling comprises two hub sections which are mounted on the machine shafts. The hub parts are connected positively by steel pins and elastomer buffers. The coupling can be fitted with add-on parts such as brake disks or brake drums.

Up to size 360, the pins and buffers are fitted on one side. From size 400 up, the pins and buffers are fitted in the hubs on alternate sides.

Materials

- Hubs:
Types RWN and RWB made of grey cast iron EN-GJL-250
Types RWS and RBS made of steel
- Flange:
Types RFN, RFS made of steel
- Pins:
Material steel 42CrMo4, surface fine-machined

- Brake disks:
Type RWB made of EN-GJS-400 spheroidal graphite cast iron
Type RBS made of steel
- Brake drums:
Type RWB made of EN-GJL-250 grey cast iron
Type RBS made of steel

8

Buffer material

Material/description	Hardness	Marking	Ambient temperature
NBR standard type	80 ShoreA	Buffer black	-30 °C ... +80 °C
NBR electrically insulating	80 ShoreA	Buffer green	-30 °C ... +80 °C
NBR soft	65 ShoreA	Buffer black with green dot	-30 °C ... +80 °C
NBR hard	90 ShoreA	Buffer black with magenta dot	-30 °C ... +80 °C
NR for low temperature	80 ShoreA	Buffer black with white dot	-50 °C ... +50 °C
HNBR high temperature	80 ShoreA	Buffer black with red dot	-10 °C ... +100 °C

RUPEX pin and bush coupling types

Type	Description
RWN	Coupling made of grey cast iron
RWS	Coupling made of steel
RWB	Coupling made of grey cast iron with brake drum or brake disk
RBS	Coupling made of steel with brake drum or brake disk
RFN	Coupling made of grey cast iron in flange-shaft variant
RFS	Coupling made of steel in flange-shaft variant

Further application-related coupling types are available. Dimension sheets for and information on these are available on request.

RUPEX pin and bush coupling types on request

Type	Description
All	Coupling with axial backlash limitation
	Coupling with pretensioned buffers
	Coupling with lengthened pins and spacer sleeves
RKS	Coupling for engaging/disengaging during standstill
RWNH, RWSH	Coupling with extension piece
RBM	Coupling with lengthened pins for sliding rotor motors
RAK	Coupling combination RUPEX with ARPEX all-steel membrane coupling

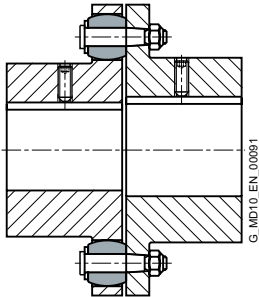

up to size 360

Types RWN/RWS – One-sided arrangement of pins and buffers

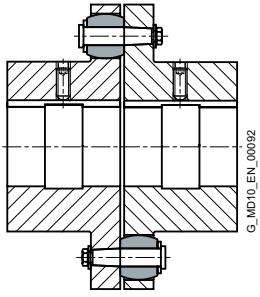

from size 400

Types RWN/RWS – Alternate-sided arrangement of pins and buffers

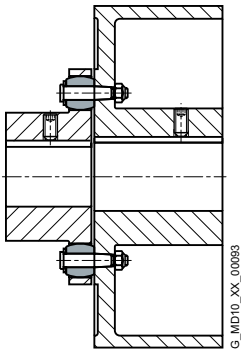

Types RWB/RBS with brake drum

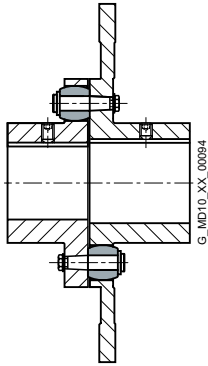

Types RWB/RBS with brake disk

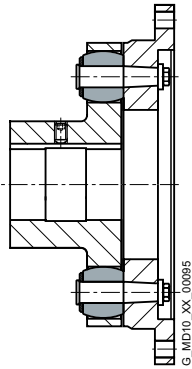

Types RFN, RFS

GENERAL

Function

The motor torque is transmitted to the hub on the drive side via the shaft-hub connection, which is mostly designed as a keyway connection. With the aid of elastomer buffers mounted on steel pins, the torque is conducted to the hub on the output side. The hub on the output side

further transmits the torque to the driven machine or a gear unit located in between. Because of the primarily compression-loaded buffers, the coupling has a progressive torsional stiffness.

Technical specifications

Power ratings									
Size	Rated torque for buffer type			Torsional stiffness at 50 % capacity utilization for buffer type			Assembly Gap dimension ΔS mm	Permitted shaft misalignment at $n = 1500 \text{ rpm}^{1)}$	
	65 ShoreA	80 ShoreA	90 ShoreA	65 ShoreA	80 ShoreA	90 ShoreA		Radial ΔK_r mm	Angle ΔK_w Degree
	T_{KN} Nm	T_{KN} Nm	T_{KN} Nm	$C_{Tdyn 50 \%}$ kNm/rad	$C_{Tdyn 50 \%}$ kNm/rad	$C_{Tdyn 50 \%}$ kNm/rad			
105	120	200	200	5	13	21	1	0.21	0.12
125	210	350	350	9	25	37	1	0.23	0.11
144	300	500	500	15	43	64	1	0.25	0.1
162	450	750	750	20	55	83	1.5	0.27	0.1
178	570	950	950	31	85	130	1.5	0.29	0.09
198	780	1300	1300	43	123	187	1.5	0.3	0.09
228	1300	2200	2200	65	184	270	1.5	0.34	0.09
252	1650	2750	2750	92	256	380	1.5	0.36	0.08
285	2600	4300	4300	141	390	560	1.5	0.4	0.08
320	3300	5500	5500	195	540	790	1.5	0.43	0.08
360	4700	7800	7800	276	610	940	1.5	0.48	0.08
400	7500	12500	12500	410	1130	1710	1.5	0.52	0.07
450	11000	18500	18500	570	1600	2380	1.5	0.57	0.07
500	15000	25000	25000	860	2350	3600	1.5	0.62	0.07
560	23500	39000	39000	1130	3070	4700	2	0.68	0.07
630	31000	52000	52000	1640	4600	7400	2	0.75	0.07
710	50000	84000	84000	2560	7200	10900	2	0.84	0.07
800	66000	110000	110000	3900	10700	16700	2	0.93	0.07
900	90000	150000	150000	5200	14300	22500	2.5	1.03	0.07
1000	115000	195000	195000	7700	21300	33000	2.5	1.14	0.07
1120	160000	270000	270000	9800	27300	44000	2.5	1.26	0.06
1250	205000	345000	345000	14000	39000	62000	2.5	1.39	0.06
1400	320000	530000	530000	22800	62000	97000	3	1.55	0.06
1600	450000	750000	750000	37000	103000	160000	3	1.76	0.06
1800	585000	975000	975000	48000	133000	208000	4	1.96	0.06
2000	780000	1300000	1300000	73000	201000	314000	4	2.17	0.06

For maximum coupling torque:

$$T_{Kmax} = 3,0 \cdot T_{KN}$$

For overload torque:

$$T_{KOL} = 4 \cdot T_{KN}$$

For coupling fatigue torque:

$$T_{KW} = 0,20 \cdot T_{KN}$$

Note

For fitting, the maximum gap dimension of $S_{max} = S + \Delta S$ and the minimum gap dimension of $S_{min} = S - \Delta S$ are permitted.

¹⁾ The maximum speed for the respective type must be noted. For additional information on the allowable shaft misalignment, please refer to the operating instructions.

Torsional stiffness and damping

The values stated in the above table apply to a capacity utilization of 50 %, an excitation amplitude of 10 % T_{KN} with the frequency 10 Hz and an ambient temperature of 20 °C. The dynamic torsional stiffness is load-dependent and increases in proportion to capacity utilization. The following table shows the correction factors for different rated loads.

$$C_{Tdyn} = C_{Tdyn} 50 \% \cdot FKC$$

	Load T_N / T_{KN}							
	20%	40%	50%	60%	70%	80%	90%	100%
Correction factor FKC 65/80/90 ShoreA	0.51	0.83	1	1.18	1.38	1.58	1.8	2.03

The damping coefficient is $\Psi = 1.4$

Torsional stiffness and damping is further dependent on the ambient temperature and the frequency and amplitude of the torsional vibration excitation. More precise torsional stiffness and damping parameters on request.

With flexible couplings the manufacturing process of the rubber elements and their aging primarily influence the stiffness value C_{Tdyn} . For this reason calculation must be made with a tolerance for the dynamic stiffness of ± 20 %. The specified damping coefficient Ψ is a minimum value with the result that the damping performance of the coupling corresponds at least to the specified value.

Permitted shaft misalignment

The permitted shaft misalignment depends on the operating speed. As the speed increases, lower shaft misalignment values are permitted. The correction factors for different speeds are specified in the following table. The maximum speed for the respective coupling size and type must be noted!

$$\Delta K_{perm} = \Delta K_{1500} \cdot FKV$$

	Speed in rpm			
	500	1000	1500	3000
Correction factor FKV	1.7	1.2	1.0	0.7

For fitting, the maximum gap dimension of $S_{max.} = S + \Delta S$ and the minimum gap dimension of $S_{min.} = S - \Delta S$ are permitted.

Shaft misalignments ΔK_r and ΔK_w may occur simultaneously.

TYPE RWN

Hub material grey cast iron

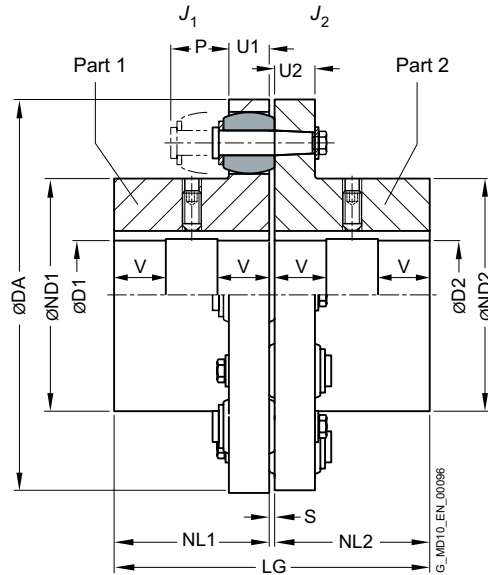

8

Size	Rated torque buffer 80 ShoreA T_{KN} Nm	Speed n_{Kmax} rpm	Dimensions in mm													Mass moment of inertia		Article no. ¹⁾	Weight <i>m</i> kg
			Bore with keyway DIN 6885 D1		DA	ND1	ND2	NL1/ NL2	S	U1	U2	P	LG	J_1 kgm ²	J_2 kgm ²				
			min.	max.												min.	max.		
105 ²⁾	200	7000	-	32	-	38	105	53	59	45	3	13	12	30	93	0.001	0.001	2LC0130-1AA	1.9
125 ²⁾	350	6000	-	40	-	48	125	65	68	50	3	16	15	35	103	0.003	0.003	2LC0130-2AA	3.2
144	500	5250	-	45	-	55	144	76	84	55	3	16	15	35	113	0.004	0.006	2LC0130-3AA	4.5
162	750	4650	-	50	-	60	162	85	92	60	3.5	20	18	40	123.5	0.007	0.013	2LC0130-4AA	6.7
178	950	4200	-	60	-	70	178	102	108	70	3.5	20	18	40	143.5	0.014	0.022	2LC0130-5AA	9.7
198	1300	3750	-	70	-	80	198	120	128	80	3.5	20	18	40	163.5	0.022	0.03	2LC0130-6AA	12.9
228	2200	3300	-	80	-	90	228	129	140	90	3.5	26	24	50	183.5	0.038	0.071	2LC0130-7AA	19
252	2750	3000	-	90	-	100	252	150	160	100	3.5	26	24	50	203.5	0.07	0.12	2LC0130-8AA	26.3
285	4300	2650	48	100	48	110	285	164	175	110	4.5	32	30	60	224.5	0.13	0.22	2LC0131-0AA	39
320	5500	2350	55	110	55	120	320	180	192	125	4.5	32	30	60	254.5	0.23	0.3	2LC0131-1AA	53
360	7800	2100	65	120	65	130	360	200	210	140	4.5	42	42	75	284.5	0.41	0.7	2LC0131-2AA	78
400	12500	2050	75	140	75	140	400	230	230	160	4.5	42	42	75	324.5	0.87	0.87	2LC0131-3AA	105
450	18500	1800	85	160	85	160	450	260	260	180	5.5	52	52	90	365.5	1.7	1.7	2LC0131-4AA	156
500	25000	1600	95	180	95	180	500	290	290	200	5.5	52	52	90	405.5	2.8	2.8	2LC0131-5AA	200
560	39000	1450	100	140	100	140	560	250	250	220	6	68	68	120	446	4.6	4.6	2LC0131-6AA	280
			140	180	140	180		300	300							5	5		290
			180	200	180	200		320	320							5.1	5.1		295
630	52000	1280	100	140	100	140	630	250	250	240	6	68	68	120	486	7.2	7.2	2LC0131-7AA	345
			140	180	140	180		300	300							7.7	7.7		370
			180	220	180	220		355	355							8.4	8.4		400
710	84000	1150	110	160	110	160	710	290	290	260	7	80	80	140	527	13	13	2LC0131-8AA	510
			160	200	160	200		330	330							14	14		515
			200	240	200	240		385	385							15	15		540

Configurable variants ¹⁾

- ØD1 Without finished bore
With finished bore
- ØD2 Without finished bore
With finished bore

¹⁾ To identify complete item numbers specifying the available finish boring options and – if necessary – further order options, please use our configurators on flender.com.

²⁾ Hub material spheroidal graphite iron EN-GJS 400.

➤ For online configuration on flender.com, click on the item no.

Size	Rated torque buffer 80 ShoreA T_{KN} Nm	Speed n_{Kmax} rpm	Dimensions in mm												Mass moment of inertia		Article no. ¹⁾	Weight m kg	
			Bore with keyway DIN 6885				DA	ND1	ND2	NL1/NL2	S	U1	U2	P	LG	J_1 kgm ²			J_2 kgm ²
			D1		D2														
min.	max.	min.	max.																
800	110000	1000	125	180	125	180	800	320	320	290	7	80	80	140	587	22	22	2LC0132-0AA	670
			180	220	180	220		360	360							23	23		690
			220	260	220	260		420	420							24.5	24.5		730
900	150000	900	140	220	140	220	900	360	360	320	7.5	90	90	160	647.5	39	39	2LC0132-1AA	940
			220	260	220	260		425	425							41	41		960
			260	290	260	290		465	465							43	43		1030
1000	195000	810	150	240	150	240	1000	395	395	350	7.5	90	90	160	707.5	60	60	2LC0132-2AA	1200
			240	280	240	280		460	460							63	63		1250
			280	320	280	320		515	515							68	68		1310
1120	270000	700	160	200	160	200	1120	360	360	380	8.5	100	100	180	768.5	98	98	2LC0132-3AA	1470
			200	250	200	250		410	410							100	100		1510
			250	300	250	300		495	495							105	105		1600
1250	345000	650	300	350	300	350	1250	560	560	420	8.5	100	100	180	848.5	110	110	2LC0132-4AA	1690
			180	230	180	230		410	410							150	150		1850
			230	280	230	280		460	460							155	155		1900
1400	530000	570	280	330	280	330	1400	540	540	480	9	120	120	210	969	165	165	2LC0132-5AA	2025
			330	380	330	380		610	610							175	175		2210
			200	260	200	260		465	465							290	290		2820
1600	750000	500	260	320	260	320	1600	525	525	540	9	120	120	210	1089	300	300	2LC0132-6AA	2900
			320	380	320	380		620	620							310	310		3180
			380	440	380	440		700	700							330	330		3260
1800	975000	450	260	320	260	320	1800	565	565	600	12	140	140	240	1212	490	490	2LC0132-7AA	3780
			320	380	320	380		720	720							500	500		3870
			380	440	380	440		770	770							530	530		4150
2000	1300000	400	440	480	440	480	2000	820	820	660	12	140	140	240	1332	550	550	2LC0132-8AA	4290
			320	380	320	380		660	660							850	850		5550
			380	440	380	440		720	720							930	930		5630
2000	1300000	400	440	500	440	500	2000	820	820	660	12	140	140	240	1332	980	980	2LC0132-8AA	6000
			500	560	500	560		870	870							1050	1050		6250
			380	440	380	440		760	760							1350	1350		6800
2000	1300000	400	440	500	440	500	2000	820	820	660	12	140	140	240	1332	1400	1400	2LC0132-8AA	7000
			500	560	500	560		920	920							1500	1500		7350
			560	600	560	600		960	960							1550	1550		7620

Configurable variants¹⁾

- ØD1 Without finished bore
With finished bore
- ØD2 Without finished bore
With finished bore

Notes

- From size 560 bores D1 and D2 are each provided with a recess of D = +1 mm halfway along the hub. V ≈ 1/3 NL
- The hub diameter of the component part is assigned according to the diameter of the finished bore. Where bore diameters overlap, the component with the smaller hub diameter is always selected.
- Weight and mass moments of inertia apply to maximum bore diameters.
- The article numbers apply to standard buffers of NBR material in the 80 ShoreA variant; the article number for alternative buffer types is available on request.

Ordering example

- RUPEX RWN coupling, size 710
- Part 1: Hub left with bore 180H7 mm, with keyway to DIN 6885 and set screw
- Part 2: Hub right with bore 200H7 mm, with keyway to DIN 6885 and set screw.

Article no.: 2LC0131-8AA99-0AA0-Z L2B+M2D

¹⁾ To identify complete item numbers specifying the available finish boring options and – if necessary – further order options, please use our configurators on flender.com.

↗ For online configuration on flender.com, click on the item no.

TYPE RWS

Hub material steel

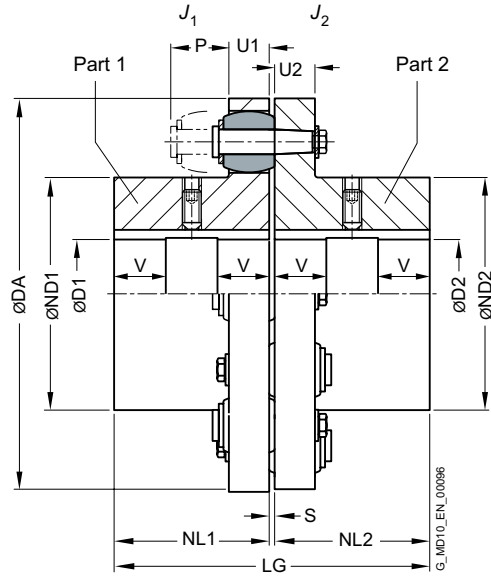

8

Size	Rated torque buffer 80 ShoreA T_{KN} Nm	Speed n_{Kmax} rpm	Dimensions in mm												Mass moment of inertia		Article no. ¹⁾	Weight m kg	
			Bore with keyway DIN 6885				DA	ND1	ND2	NL1/ NL2	S	U1	U2	P	LG	J_1 kgm ²			J_2 kgm ²
			D1	D2	min.	max.													
105	200	10000	-	32	-	38	105	53	59	45	3	13	12	30	93	0.001	0.001	2LC0130-1AB	1.9
125	350	9000	-	42	-	48	125	65	68	50	3	16	15	35	103	0.003	0.003	2LC0130-2AB	3.2
144	500	7800	-	50	-	60	144	76	84	55	3	16	15	35	113	0.004	0.006	2LC0130-3AB	4.5
162	750	6900	-	55	-	65	162	85	92	60	3.5	20	18	40	123.5	0.007	0.013	2LC0130-4AB	6.7
178	950	6300	-	70	-	75	178	102	108	70	3.5	20	18	40	143.5	0.014	0.022	2LC0130-5AB	9.7
198	1300	5600	-	80	-	85	198	120	128	80	3.5	20	18	40	163.5	0.022	0.030	2LC0130-6AB	12.9
228	2200	4900	-	85	-	95	228	129	140	90	3.5	26	24	50	183.5	0.038	0.071	2LC0130-7AB	19
252	2750	4400	-	100	-	110	252	150	160	100	3.5	26	24	50	203.5	0.07	0.12	2LC0130-8AB	26.3
285	4300	3900	-	110	-	120	285	164	175	110	4.5	32	30	60	224.5	0.13	0.21	2LC0131-0AB	39
320	5500	3500	55	125	55	130	320	180	192	125	4.5	32	30	60	254.5	0.23	0.32	2LC0131-1AB	53
360	7800	3100	65	135	65	140	360	200	210	140	4.5	42	42	75	284.5	0.41	0.69	2LC0131-2AB	78
400	12500	2800	75	150	75	150	400	230	230	160	4.5	42	42	75	324.5	0.92	0.92	2LC0131-3AB	110
450	18500	2500	85	170	85	170	450	260	260	180	5.5	52	52	90	365.5	1.7	1.7	2LC0131-4AB	163
500	25000	2200	95	190	95	190	500	290	290	200	5.5	52	52	90	405.5	2.8	2.8	2LC0131-5AB	217
560	39000	2000	100	165	100	165		250	250							4.8	4.8		274
			165	200	165	200	560	300	300	220	6	68	68	120	446	5.2	5.2	2LC0131-6AB	292
			200	210	200	210		320	320							5.4	5.4		305
630	52000	1800	100	165	100	165		250	250							7.6	7.6		352
			165	200	165	200	630	300	300	240	6	68	68	120	486	7.9	7.9	2LC0131-7AB	370
			200	235	200	235		355	355							8.7	8.7		400
710	84000	1600	110	190	110	190		290	290							14.4	14.4		507
			190	220	190	220	710	330	330	260	7	80	80	140	527	14.6	14.6	2LC0131-8AB	530
			220	250	220	250		385	385							15.9	15.9		560

Configurable variants ¹⁾

- ØD1 Without finished bore
With finished bore
- ØD2 Without finished bore
With finished bore

¹⁾ To identify complete item numbers specifying the available finish boring options and – if necessary – further order options, please use our configurators on flender.com.

➤ For online configuration on flender.com, click on the item no.

Size	Rated torque buffer 80 ShoreA T_{KN} Nm	Speed n_{Kmax} rpm	Dimensions in mm												Mass moment of inertia		Article no. ¹⁾	Weight m kg	
			Bore with keyway DIN 6885				DA	ND1	ND2	NL1/ NL2	S	U1	U2	P	LG	J_1 kgm ²			J_2 kgm ²
			D1		D2														
min.	max.	min.	max.																
800	110000	1400	125	210	125	210	800	320	320	290	7	80	80	140	587	23.1	23.1	2LC0132-0AB	683
			210	240	210	240		360	360							23.3	23.3		715
			240	280	240	280		420	420							25.7	25.7		762
900	150000	1250	140	210	140	210	900	320	320	320	7.5	90	90	160	647.5	40	40	2LC0132-1AB	907
			210	240	210	240		360	360							41	41		933
			240	280	240	280		425	425							44	44		1000
1000	195000	1100	280	310	280	310	1000	465	465	350	7.5	90	90	160	707.5	45	45	2LC0132-2AB	1025
			150	230	150	230		355	355							63	63		1170
			230	260	230	260		395	395							64	64		1208
1120	270000	1000	260	300	260	300	1120	460	460	380	8.5	100	100	180	768.5	68	68	2LC0132-3AB	1290
			300	340	300	340		515	515							70	70		1343
			160	240	160	240		360	360							105	105		1560
1250	345000	900	240	270	240	270	1250	410	410	420	8.5	100	100	180	848.5	106	106	2LC0132-4AB	1660
			270	330	270	330		495	495							109	109		1730
			330	370	330	370		560	560							119	119		1870
1400	530000	800	180	270	180	270	1400	410	410	480	9	120	120	210	969	168	168	2LC0132-5AB	2000
			270	300	270	300		460	460							172	172		2150
			300	360	300	360		540	540							179	179		2200
1600	750000	700	360	400	360	400	1600	610	610	540	9	120	120	210	1089	189	189	2LC0132-6AB	2420
			200	310	200	310		465	465							316	316		3020
			310	350	310	350		525	525							322	322		3120
1800	975000	600	350	410	350	410	1800	620	620	600	12	140	140	240	1212	337	337	2LC0132-7AB	3350
			410	460	410	460		700	700							357	357		3570
			260	370	260	370		565	565							540	540		3890
2000	1300000	550	370	410	370	410	2000	625	625	660	12	140	140	240	1332	554	554	2LC0132-8AB	4270
			410	480	410	480		720	720							587	587		4300
			480	510	480	510		770	770							611	611		4630
1800	975000	600	320	440	320	440	1800	660	660	600	12	140	140	240	1212	1043	1043	2LC0132-7AB	6230
			440	480	440	480		720	720							1072	1072		6460
			480	540	480	540		820	820							1122	1122		6770
2000	1300000	550	540	580	540	580	2000	870	870	660	12	140	140	240	1332	1143	1143	2LC0132-8AB	7030
			380	500	380	500		760	760							1628	1628		8140
			500	540	500	540		820	820							1664	1664		8430
2000	1300000	550	540	610	540	610	2000	920	920	660	12	140	140	240	1332	1735	1735	2LC0132-8AB	8860
			610	640	610	640		960	960							1793	1793		9050

Configurable variants¹⁾

- ØD1 Without finished bore
With finished bore
- ØD2 Without finished bore
With finished bore

Notes

- From size 560 bores D1 and D2 are each provided with a recess of D = +1 mm halfway along the hub. V ≈ 1/3 NL
- The hub diameter of the component part is assigned according to the diameter of the finished bore. Where bore diameters overlap, the component with the smaller hub diameter is always selected.
- Weight and mass moments of inertia apply to maximum bore diameters.
- The article numbers apply to standard buffers of NBR material in the 80 ShoreA variant; the article number for alternative buffer types is available on request.

Ordering example

- RUPEX RWS coupling, size 710
- Part 1: Hub left with bore 180H7 mm, with keyway to DIN 6885 and set screw
- Part 2: Hub right with bore 200H7 mm, with keyway to DIN 6885 and set screw.
- Coupling micro-balanced G6.3 at 1500 rpm in accordance with half parallel key standard

Article no.: 2LC0131-8AB99-0AA0-Z L2B+M2D+W02+Y95
Plain text to Y95: G 6.3 N, n = 1500 rpm

¹⁾ To identify complete item numbers specifying the available finish boring options and – if necessary – further order options, please use our configurators on flender.com.

➤ For online configuration on flender.com, click on the item no.

TYPE RFN

Hub material grey cast iron

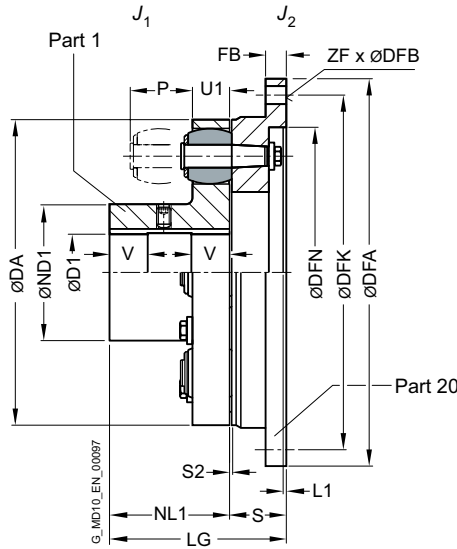

8

Size	Rated torque buffer 80 ShoreA T_{KN} Nm	Speed n_{Kmax} rpm	Dimensions in mm													Mass moment of inertia		Article no. ¹⁾	Weight m kg			
			Bore with keyway DIN 6885 D1 min. max.		DA	ND1	NL1	S	LG	Flange connection						J_1 kgm ²	J_2 kgm ²					
105	200	7000	-	32	105	53	45	26	71	158	10					142	6	9	0.001	0.005	2LC0130-1AJ	2.3
125	350	6000	-	40	125	65	50	31	81	180	13					160	6	11	0.003	0.012	2LC0130-2AJ	4.2
144	500	5250	-	45	144	76	55	31	86	200	13					180	7	11	0.004	0.018	2LC0130-3AJ	5.0
162	750	4650	-	50	162	85	60	37.5	97.5	220	13					200	8	11	0.007	0.032	2LC0130-4AJ	7.3
178	950	4200	-	60	178	102	70	37.5	107.5	248	16					224	8	14	0.014	0.055	2LC0130-5AJ	10
198	1300	3750	-	70	198	120	80	37.5	117.5	274	16					250	8	14	0.022	0.08	2LC0130-6AJ	13
228	2200	3300	-	80	228	129	90	45.5	135.5	314	20					282	8	18	0.038	0.18	2LC0130-7AJ	20
252	2750	3000	-	90	252	150	100	45.5	145.5	344	20					312	8	18	0.07	0.26	2LC0130-8AJ	25
285	4300	2650	48	100	285	164	110	55.5	165.5	380	22					348	9	18	0.13	0.46	2LC0131-0AJ	38
320	5500	2350	55	110	320	180	125	55.5	175.5	430	25					390	9	22	0.23	0.76	2LC0131-1AJ	50
360	7800	2100	65	120	360	200	140	70.5	210.5	480	25					440	10	22	0.41	1.4	2LC0131-2AJ	76
400	12500	2050	75	140	400	230	160	74.5	234.5	520	50	380	4	480	10	22	0.87	1.8	2LC0131-3AJ	125		
450	18500	1800	85	160	450	260	180	85.5	265.5	575	45	428	6	528	12	26	1.7	3.2	2LC0131-4AJ	170		
500	25000	1600	95	180	500	290	200	85.5	285.5	620	45	475	6	570	12	26	2.8	4.3	2LC0131-5AJ	205		

Configurable variants ¹⁾

- ØD1 Without finished bore
With finished bore

¹⁾ To identify complete item numbers specifying the available finish boring options and – if necessary – further order options, please use our configurators on flender.com.

↗ For online configuration on flender.com, click on the item no.

Size	Rated torque buffer 80 ShoreA	Speed	Dimensions in mm													Mass moment of inertia		Article no. ¹⁾	Weight		
			Bore with keyway DIN 6885		DA	ND1	NL1	S	LG	Flange connection						J ₁ kgm ²	J ₂ kgm ²			m kg	
T _{KN} Nm	n _{Kmax} rpm	D1 min.	D1 max.	DFN h8						FB	DFN H7	L1	DFK	ZF	DFB			DFN h8	FB		DFN H7
560	39000	1450	100	140	560	250	220	106	326	700	65	532	8	650	16	26	4.6	8.2	2LC0131-6AJ	330	
			140	180		300											320			5	330
			180	200		320											5.1			340	
630	52000	1280	100	140	630	250	240	106	346	785	60	602	8	725	16	33	7.2	13.8	2LC0131-7AJ	390	
			140	180		300											355			7.7	400
			180	220		355											8.4			420	
710	84000	1150	110	160	710	290	260	127	387	875	80	675	10	815	18	33	13	26	2LC0131-8AJ	550	
			160	200		330											385			14	550
			200	240		385											15			570	
800	110000	1000	125	180	800	320	290	127	417	1000	70	765	10	930	16	39	22	45	2LC0131-9AJ	680	
			180	220		360											23			690	
			220	260		420											24.5			710	

Configurable variants ¹⁾

- ØD1 Without finished bore
With finished bore

Notes

- For dimensions U1, P and S2, see type RWN on Page 8/8
- From size 560 bore D1 is provided with a recess of D = +1 mm halfway along the hub.
V ≈ 1/3 NL
- Weight and mass moments of inertia apply to maximum bore diameters.
- The article numbers apply to standard buffers of NBR material in the 80 ShoreA variant; the article number for alternative buffer types is available on request.

Ordering example

- RUPEX RFN coupling, size 560
- Part 1: Hub left with bore 180H7 mm, with keyway to DIN 6885 and set screw

Article no.: 2LC0131-6AJ91-0AA0-Z L2B

¹⁾ To identify complete item numbers specifying the available finish boring options and – if necessary – further order options, please use our configurators on flender.com.

➤ For online configuration on flender.com, click on the item no.

TYPE RFS

Hub material steel

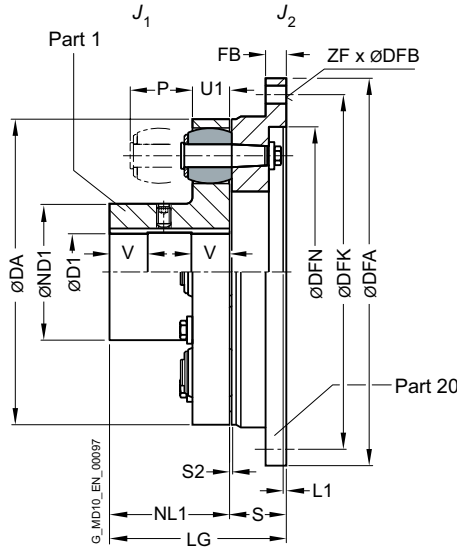

8

Size	Rated torque buffer 80 ShoreA T_{KN} Nm	Speed n_{Kmax} rpm	Dimensions in mm													Mass moment of inertia		Article no. ¹⁾	Weight m kg	
			Bore with keyway DIN 6885 D1 min. max.		DA	ND1	NL1	S	LG	Flange connection					J_1 kgm ²	J_2 kgm ²				
										DFA h8	FB	DFN H7	L1	DFK	ZF	DFB				
105	200	10000	-	32	105	53	45	26	71	158	10			142	6	9	0.001	0.005	2LC0130-1AK	2.3
125	350	9000	-	42	125	65	50	31	81	180	13			160	6	11	0.003	0.012	2LC0130-2AK	4.2
144	500	7800	-	50	144	76	55	31	86	200	13			180	7	11	0.004	0.018	2LC0130-3AK	5
162	750	6900	-	55	162	85	60	37.5	97.5	220	13			200	8	11	0.007	0.032	2LC0130-4AK	7.3
178	950	6300	-	70	178	102	70	37.5	107.5	248	16			224	8	14	0.014	0.055	2LC0130-5AK	10
198	1300	5600	-	80	198	120	80	37.5	117.5	274	16			250	8	14	0.022	0.08	2LC0130-6AK	13
228	2200	4900	-	85	228	129	90	45.5	135.5	314	20			282	8	18	0.038	0.18	2LC0130-7AK	20
252	2750	4400	-	100	252	150	100	45.5	145.5	344	20			312	8	18	0.07	0.26	2LC0130-8AK	25
285	4300	3900	48	110	285	164	110	55.5	165.5	380	22			348	9	18	0.13	0.46	2LC0131-0AK	38
320	5500	3500	55	125	320	180	125	55.5	175.5	430	25			390	9	22	0.23	0.76	2LC0131-1AK	50
360	7800	3100	65	135	360	200	140	70.5	210.5	480	25			440	10	22	0.41	1.4	2LC0131-2AK	76
400	12500	2800	75	150	400	230	160	74.5	234.5	520	50	380	4	480	10	22	0.92	1.8	2LC0131-3AK	125
450	18500	2500	85	170	450	260	180	85.5	265.5	575	45	428	6	528	12	26	1.7	3.2	2LC0131-4AK	175
500	25000	2200	95	190	500	290	200	85.5	285.5	620	45	475	6	570	12	26	2.8	4.3	2LC0131-5AK	210

Configurable variants ¹⁾

- ØD1 Without finished bore
With finished bore

¹⁾ To identify complete item numbers specifying the available finish boring options and – if necessary – further order options, please use our configurators on flender.com.

↗ For online configuration on flender.com, click on the item no.

Size	Rated torque buffer 80 ShoreA	Speed n_{Kmax} rpm	Dimensions in mm														Mass moment of inertia		Article no. ¹⁾	Weight m kg	
			Bore with keyway DIN 6885		DA	ND1	NL1	S	LG	Flange connection						J_1 kgm ²	J_2 kgm ²				
			D1 min.	max.						DFA h8	FB	DFN H7	L1	DFK	ZF			DFB			
560	39000	2000	100	165	560	250	220	106	326	700	65	532	8	650	16	26	4.8	8.2	2LC0131-6AK	330	
			165	200		300											320			5.2	340
			200	210		320											5.4			340	
630	52000	1800	100	165	630	250	240	106	346	785	60	602	8	725	16	33	7.6	13.8	2LC0131-7AK	390	
			165	200		300											355			7.9	400
			200	235		355											8.7			420	
710	84000	1600	110	190	710	290	260	127	387	875	80	675	10	815	18	33	14.4	26	2LC0131-8AK	550	
			190	220		330											385			14.6	560
			220	250		385											15.9			580	
800	110000	1400	125	210	800	320	290	127	417	1000	70	765	10	930	16	39	23.1	45	2LC0131-9AK	690	
			210	240		360											420			23.3	710
			240	280		420											25.7			730	

Configurable variants ¹⁾

- ØD1 Without finished bore
With finished bore

Notes

- For dimensions U1, P and S2, see type RWS on Page 8/10
- From size 560 bore D1 is provided with a recess of D = +1 mm halfway along the hub.
 $V \approx 1/3 NL$
- Weight and mass moments of inertia apply to maximum bore diameters.
- The article numbers apply to standard buffers of NBR material in the 80 ShoreA variant; the article number for alternative buffer types is available on request.

Ordering example

- RUPEX RFS coupling, size 560
- Part 1: Hub left with bore 180H7 mm, with keyway to DIN 6885 and set screw
- Coupling micro-balanced G6.3 at 1500 rpm in accordance with half parallel key standard

Article no.: 2LC0131-6AK91-0AA0-Z L2B+W02+Y95
Plain text to Y95: G 6.3 N, n = 1500 rpm

¹⁾ To identify complete item numbers specifying the available finish boring options and – if necessary – further order options, please use our configurators on flender.com.

➤ For online configuration on flender.com, click on the item no.

TYPE RWB

with brake disk to DIN 15432

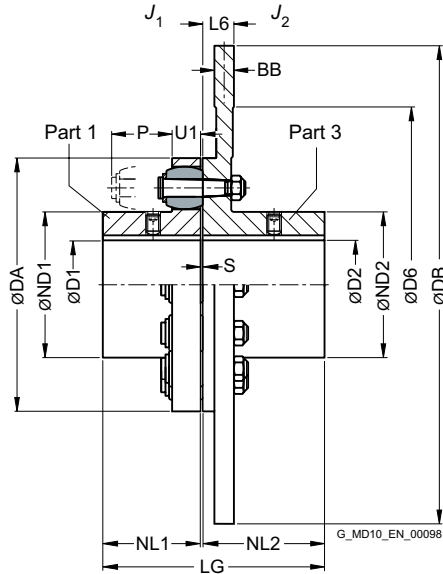

8

Size	Rated torque buffer 80 ShoreA T_{KN} Nm	Dimensions in mm															Article no. ¹⁾			
		Bore with keyway DIN 6885				Coupling									Brake disk					
		D1		D2		DA	ND1	ND2	NL1	NL2	S	U1	P	LG	DB ²⁾	DB	D6	BB ²⁾	L6	
		min.	max.	min.	max.					max.				max.	max.	min.	min.	min.	min.	
144	500	-	45	-	45	144	76	84	55	219	3	16	35	277	500	315	175	30	34	2LC0130-3AE
162	750	-	50	-	50	162	85	92	60	219	3.5	20	40	282.5	560	315	175	30	34	2LC0130-4AE
178	950	-	60	-	60	178	102	108	70	219	3.5	20	40	292.5	560	355	200	30	34	2LC0130-5AE
198	1300	-	70	-	70	198	120	128	80	219	3.5	20	40	302.5	560	355	200	30	34	2LC0130-6AE
228	2200	-	80	-	80	228	129	140	90	219	3.5	26	50	312.5	800	355	250	30	34	2LC0130-7AE
252	2750	-	90	38	100	252	150	160	100	219	3.5	26	50	322.5	800	400	280	30	34	2LC0130-8AE
285	4300	48	100	48	110	285	164	175	110	219	4.5	32	60	333.5	800	400	310	30	34	2LC0131-0AE
320	5500	55	110	55	120	320	180	192	125	219	4.5	32	60	348.5	1000	450	350	30	34	2LC0131-1AE

Configurable variants ¹⁾

- ØD1 Without finished bore
With finished bore
- ØD2 Without finished bore
With finished bore

¹⁾ To identify complete item numbers specifying the available finish boring options and – if necessary – further order options, please use our configurators on flender.com.

²⁾ For the available DB·BB brake disk dimensions, please refer to the product configurator on flender.com.

↗ For online configuration on flender.com, click on the item no.

Notes

- Brake disk diameter DB in accordance with customer specification.
- Additional sizes are available on request.
- Further dimensions for part 3 on request.
- Maximum speed in rpm:
 $n_{K_{max}} = 1146/DB$ (DB in m)
 Observe maximum speed of type RWN!
- Mass moments of inertia and weights can be sufficiently precisely determined as follows:
 - Mass moments of inertia in kgm^2 :
 $J_1 = J_1$ from type RWN
 $J_2 = J_2$ from type RWN + $710 \times BB \times DB^4$
 (BB and DB in m)
 - Weight in kg:
 $m = m$ from type RWN + $5700 \times BB \times DB^2$
 (BB and DB in m)
- The article numbers apply to standard buffers of NBR material in the 80 ShoreA variant; the article number for alternative buffer types is available on request.

Ordering example

- RUPEX RWB coupling, size 252, brake disk 630 x 30 mm
- Part 1: Bore D1 = 48H7 mm, keyway to DIN 6885-1 and set screw
- Part 3: Bore 42H7 mm, keyway to DIN 6885-1 P9 and set screw.
- Coupling micro-balanced G6.3 at 1500 rpm in accordance with half parallel key standard
- Mass moment of inertia:
 $J_1 = 0.07 \text{ kgm}^2$
 $J_2 = 0.12 \text{ kgm}^2 + 3.3 \text{ kgm}^2 = 3.42 \text{ kgm}^2$
- Weight:
 $m = 26.3 \text{ kg} + 68 \text{ kg} = 94.3 \text{ kg}$

Article no.: 2LC0130-8AE99-0KA0-Z L1B+M0X+W02+Y95
 Plain text to Y95: G 6.3 N, n = 1500 rpm

¹⁾ To identify complete item numbers specifying the available finish boring options and – if necessary – further order options, please use our configurators on flender.com.

²⁾ For the available DB·BB brake disk dimensions, please refer to the product configurator on flender.com.

➤ For online configuration on flender.com, click on the item no.

TYPE RBS

with brake disk to DIN 15432

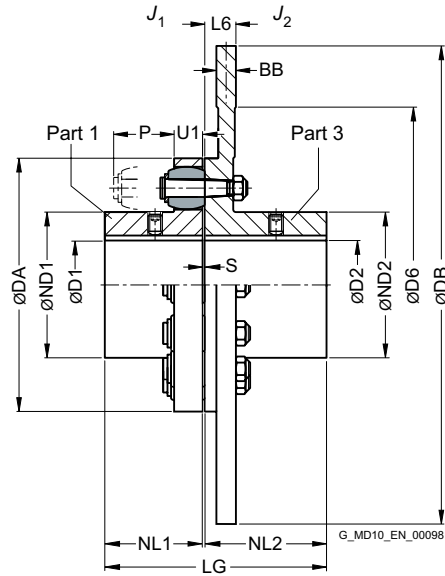

8

Size	Rated torque buffer 80 ShoreA T_{KN} Nm	Dimensions in mm																Article no. ¹⁾	
		Bore with keyway DIN 6885				Brake disk													
		D1		D2		DA	ND1	ND2	NL1	NL2	S	U1	P	LG	DB ²⁾	D6	BB ²⁾	L6	
		min.	max.	min.	max.					max.				max.	min.	min.			
144	500	-	50	-	45	144	76	84	55	219	3	16	35	277	315	175	30	34	2LC0130-3AH
162	750	-	55	-	50	162	85	92	60	219	3.5	20	40	282.5	315	175	30	34	2LC0130-4AH
178	950	-	70	-	60	178	102	108	70	219	3.5	20	40	292.5	355	200	30	34	2LC0130-5AH
198	1300	-	80	-	70	198	120	128	80	219	3.5	20	40	302.5	355	200	30	34	2LC0130-6AH
228	2200	-	85	-	80	228	129	140	90	219	3.5	26	50	312.5	355	250	30	34	2LC0130-7AH
252	2750	-	100	38	100	252	150	160	100	219	3.5	26	50	322.5	400	280	30	34	2LC0130-8AH
285	4300	48	110	48	120	285	164	175	110	219	4.5	32	60	333.5	400	310	30	34	2LC0131-0AH
320	5500	55	125	55	130	320	180	192	125	219	4.5	32	60	348.5	450	350	30	34	2LC0131-1AH
360	7800	65	135	65	140	360	200	210	140	221	4.5	42	75	365.5	560	390	30	36	2LC0131-2AE

Configurable variants ¹⁾

- ØD1 Without finished bore
With finished bore
- ØD2 Without finished bore
With finished bore

¹⁾ To identify complete item numbers specifying the available finish boring options and – if necessary – further order options, please use our configurators on flender.com.

²⁾ For the available DB- BB brake disk dimensions, please refer to the product configurator on flender.com.

↗ For online configuration on flender.com, click on the item no.

Notes

- Brake disk diameter DB in accordance with customer specification.
- Additional sizes are available on request.
- Further dimensions for part 3 on request.
- Maximum speed in rpm:
 $n_{Kmax} = 1528/DB$ (DB in m)
 Observe maximum speed of type RWS!
- Mass moments of inertia and weights can be sufficiently precisely determined as follows:
 - Mass moments of inertia in kgm^2 :
 $J_1 = J_1$ from type RWS
 $J_2 = J_2$ from type RWS + $770 \times BB \times DB^4$
 (BB and DB in m)
 - Weight in kg:
 $m = m$ from type RWS + $6160 \times BB \times DB^2$
 (BB and DB in m)
- The article numbers apply to standard buffers of NBR material in the 80 ShoreA variant; the article number for alternative buffer types is available on request.

Ordering example

- RUPEX RBS coupling, size 252, brake disk 630 x 30 mm
- Part 1: Bore D1 = 48H7 mm, keyway to DIN 6885-1 and set screw
- Part 3: Bore 42H7 mm, keyway to DIN 6885-1 P9 and set screw.
- Coupling micro-balanced G6.3 at 1500 rpm in accordance with the half parallel key standard.
- Mass moment of inertia:
 $J_1 = 0.07 \text{ kgm}^2$
 $J_2 = 0.12 \text{ kgm}^2 + 3.6 \text{ kgm}^2 = 3.72 \text{ kgm}^2$
- Weight:
 $m = 25.8 \text{ kg} + 73 \text{ kg} = 98.8 \text{ kg}$

Article no.: **2LC0130-8AH99-0KA0-Z L1B+M0X+W02+Y95**
 Plain text to Y95: **G 6.3 N, n = 1500 rpm**

¹⁾ To identify complete item numbers specifying the available finish boring options and – if necessary – further order options, please use our configurators on flender.com.

²⁾ For the available DB·BB brake disk dimensions, please refer to the product configurator on flender.com.

➤ For online configuration on flender.com, click on the item no.

TYPE RBS

with brake disk to DIN 15432

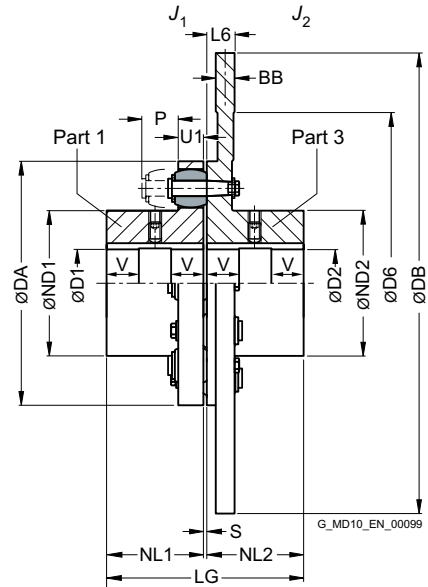

8

Size	Rated torque buffer 80 ShoreA T_{KN} Nm	Dimensions in mm														Brake disk			Article no. ¹⁾
		Bore with keyway DIN 6885				DA	ND1	ND2	NL1	NL2	S	U1	P	LG	D6 ²⁾ min.	BB ²⁾	L6		
		D1 min.	D1 max.	D2 min.	D2 max.														
400	12500	75	150	75	150	400	230	230	160	225	4.5	42	75	389.5	410	30	40	2LC0131-3AH	
450	18500	85	170	85	170	450	260	260	180	225	5.5	52	90	410.5	460	30	40	2LC0131-4AH	
500	25000	95	190	95	190	500	290	290	200	225	5.5	52	90	430.5	510	30	40	2LC0131-5AH	
560	39000	100	165	100	210	560	250	320	220	225	6	68	120	451	570	30	40	2LC0131-6AH	
		165	200				300												
		200	210				320												
630	52000	100	165	100	235	630	250	355	240	240	6	68	120	486	670	30	55	2LC0131-7AH	
		165	200				300												
		200	235				355												

Configurable variants ¹⁾

- ØD1 Without finished bore
With finished bore
- ØD2 Without finished bore
With finished bore

¹⁾ To identify complete item numbers specifying the available finish boring options and – if necessary – further order options, please use our configurators on flender.com.

²⁾ For the available DB · BB brake disk dimensions, please refer to the product configurator on flender.com.

➤ For online configuration on flender.com, click on the item no.

Size	Rated torque buffer 80 ShoreA T_{KN} Nm	Dimensions in mm															Article no. ¹⁾	
		Bore with keyway DIN 6885				DA	ND1	ND2	NL1	NL2	S	U1	P	LG	Brake disk			
		D1 min.	D1 max.	D2 min.	D2 max.										D6 ²⁾ min.	BB ²⁾		L6
710	84000	110	190	110	250	710	290	385	260	260	7	80	140	527	760	30	75	2LC0131-8AH
		190	220				330											
		220	250				385											
800	110000	125	210	125	280	800	320	420	290	290	7	80	140	587	840	30	75	2LC0132-0AH
		210	240				360											
		240	280				420											
900	150000	140	210	140	310	900	320	465	320	-	7.5	90	160	647.5	950	30	75	2LC0132-1AH
		210	240				360											
		240	280				425											
		280	310				465											
1000	195000	150	230	150	340	1000	355	515	350	-	7.5	90	160	707.5	1050	30	75	2LC0132-2AH
		230	260				395											
		260	300				460											
		300	340				515											

Configurable variants¹⁾

- ØD1 Without finished bore
With finished bore
- ØD2 Without finished bore
With finished bore

Notes

- From size 560 bores D1 are provided with a recess of D = +1 mm halfway along the hub.
 $V \approx 1/3 NL$
- Brake disk diameter DB in accordance with customer specification.
- Additional sizes are available on request. Further dimensions for part 3 on request.
- Maximum speed in rpm:
 $n_{Kmax} = 1528/DB$ (DB in m)
Observe maximum speed of type RWS!
- Mass moments of inertia and weights can be sufficiently precisely determined as follows:
 - Mass moments of inertia in kgm²:
 $J_1 = J_1$ from type RWS
 $J_2 = J_2$ from type RWS + $770 \times BB \times DB^4$ (BB and DB in m)
 - Weight in kg:
 $m = m$ from type RWS + $6160 \times BB \times DB^2$ (BB and DB in m)
- The article numbers apply to standard buffers of NBR material in the 80 ShoreA variant; the article number for alternative buffer types is available on request.

Ordering example

- RUPEX RBS coupling, size 450, brake disk 900 x 30 mm
- Part 1: Bore D1 = 130H7 mm, keyway to DIN 6885-1 and set screw
- Part 3: Bore 120H7 mm, keyway to DIN 6885-1 P9 and set screw.
- Coupling micro-balanced G6.3 at 1500 rpm in accordance with half parallel key standard
- Mass moment of inertia:
 $J_1 = 1.74 \text{ kgm}^2$
 $J_2 = 1.74 \text{ kgm}^2 + 15 \text{ kgm}^2 = 16.74 \text{ kgm}^2$
- Weight:
 $m = 25.8 \text{ kg} + 149 \text{ kg} = 174.8 \text{ kg}$

Article no.: 2LC0131-4AH99-0NA0-Z L1U+M1S+W02+Y95
Plain text to Y95: G 6.3 N, n = 1500 rpm

¹⁾ To identify complete item numbers specifying the available finish boring options and – if necessary – further order options, please use our configurators on flender.com.

²⁾ For the available DB · BB brake disk dimensions, please refer to the product configurator on flender.com.

➤ For online configuration on flender.com, click on the item no.

TYPE RWB

with brake drum to DIN 15431

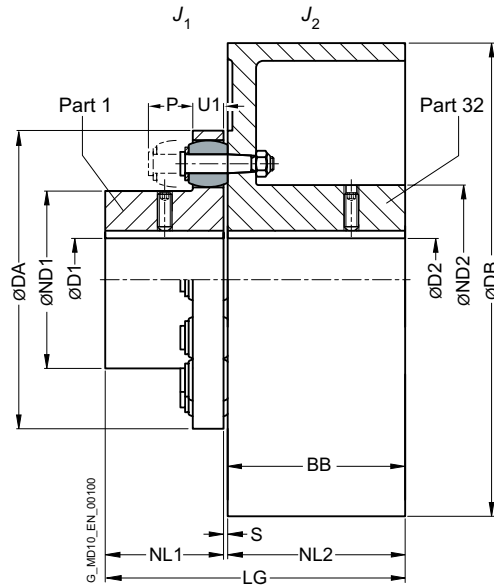

8

Size	Rated torque buffer 80 ShoreA T_{KN} Nm	Speed n_{Kmax} rpm	Dimensions in mm											Mass moment of inertia		Article no. ¹⁾	Weight m kg		
			Bore with keyway DIN 6885			DA	ND1	ND2	NL1	NL2/BB	S	DB	LG	J_1	J_2				
			D1 min.	D1 max.	D2 min.	D2 max.													
144	500	4800	-	45	-	55	144	76	84	55	75	3	200	133	133	0.004	0.04	2LC0130-3AC	9.5
162	750	3800	-	50	-	60	162	85	92	60	95	3.5	250	158.5	158.5	0.007	0.11	2LC0130-4AC	17
		3000	-	60	-	70	178	102	108	70	95	3.5	250	168.5	191.5	0.014	0.31	2LC0130-5AC	28
178	950	3800	-	60	-	70	178	102	108	70	95	3.5	250	168.5	191.5	0.014	0.31	2LC0130-5AC	28
		3000	-	70	-	80	198	120	128	80	95	3.5	250	178.5	201.5	0.022	0.32	2LC0130-6AC	32
198	1300	3800	-	70	-	80	198	120	128	80	95	3.5	250	178.5	201.5	0.022	0.32	2LC0130-6AC	32
		3000	-	80	-	90	228	129	140	90	150	3.5	400	243.5	243.5	0.038	1	2LC0130-7AC	54
228	2200	2400	-	80	-	90	228	129	140	90	150	3.5	400	243.5	243.5	0.038	1	2LC0130-7AC	54
		1900	-	90	38	100	252	150	160	100	150	3.5	400	253.5	293.5	0.07	2.8	2LC0130-8AC	93
252	2750	2400	-	90	38	100	252	150	160	100	150	3.5	400	253.5	293.5	0.07	2.8	2LC0130-8AC	93
		1900	-	100	48	110	285	164	175	110	190	4.5	500	304.5	304.5	0.13	7.8	2LC0131-0AC	104
285	4300	1900	48	100	48	110	285	164	175	110	190	4.5	500	304.5	304.5	0.13	7.8	2LC0131-0AC	104
		1500	55	110	55	120	320	180	192	125	236	4.5	630	365.5	365.5	0.23	13.9	2LC0131-1AC	172
320	5500	1500	55	110	55	120	320	180	192	125	236	4.5	630	365.5	365.5	0.23	13.9	2LC0131-1AC	217
		1300	65	120	65	130	360	200	210	140	236	4.5	630	380.5	380.5	0.41	8.1	2LC0131-2AC	191
360	7800	1500	65	120	65	130	360	200	210	140	236	4.5	630	380.5	380.5	0.41	8.1	2LC0131-2AC	191
		1300	-	130	65	130	360	200	210	140	265	4.5	710	409.5	409.5	0.41	14	2LC0131-2AC	236

Configurable variants ¹⁾

- ØD1 Without finished bore
With finished bore
- ØD2 Without finished bore
With finished bore

Note

- For dimensions U1 and P, see type RWN on Page 8/8.
- Weight and mass moments of inertia apply to maximum bore diameters.
- The article numbers apply to standard buffers of NBR material in the 80 ShoreA variant; the article number for alternative buffer types is available on request.

Ordering example

- RUPEX RWB coupling, size 252
- Part 1: Bore 48H7 mm, keyway to DIN 6885-1 and set screw
- Part 3: 500 x 190, bore 42H7 mm, keyway to DIN 6885-1 P9 and set screw.
- Coupling micro-balanced G6.3 at 1500 rpm in accordance with half parallel key standard

Article no.: 2LC0130-8AC99-0FA0-Z L1B+M0X+W02+Y95
Plain text to Y95: G 6.3 N, n = 1500 rpm

¹⁾ To identify complete item numbers specifying the available finish boring options and – if necessary – further order options, please use our configurators on flender.com.

➤ For online configuration on flender.com, click on the item no.

TYPE RBS

with brake drum to DIN 15431

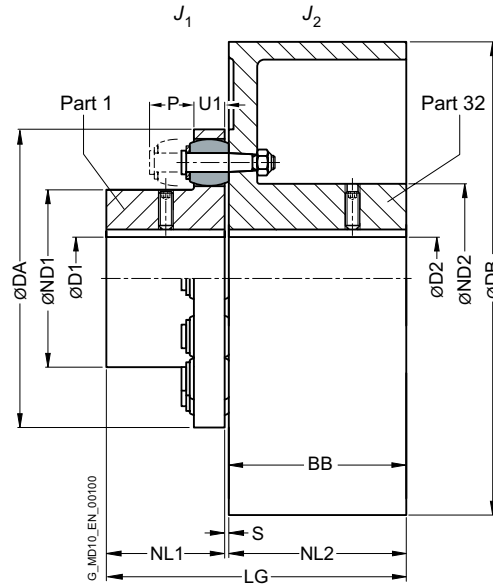

Size	Rated torque buffer 80 ShoreA T_{KN} Nm	Speed n_{Kmax} rpm	Dimensions in mm											Mass moment of inertia		Article no. ¹⁾	Weight m kg	
			Bore with keyway DIN 6885				DA	ND1	ND2	NL1	NL2/ BB	S	DB	LG	J_1 kgm ²			J_2 kgm ²
			D1 min.	D1 max.	D2 min.	D2 max.												
144	500	5000	-	50	-	60	144	76	84	55	75	3	200	133	0.004	0.04	2LC0130-3AD	10
162	750	5000	-	55	-	65	162	85	92	60	95	3.5	250	158.5	0.007	0.13	2LC0130-4AD	18
178	950	4900	-	70	-	75	178	102	108	70	95	3.5	250	168.5	0.014	0.13	2LC0130-5AD	22
		4350									118		315	191.5		0.34	2LC0130-5AD	30
198	1300	4600	-	80	-	85	198	120	128	80	95	3.5	250	178.5	0.022	0.14	2LC0130-6AD	26
		4350									118		315	201.5		0.35	2LC0130-6AD	35
228	2200	3400	-	85	-	95	228	129	140	90	150	3.5	400	243.5	0.038	1.1	2LC0130-7AD	60
252	2750	3400	-	100	38	110	252	150	160	100	150	3.5	400	253.5	0.067	1.1	2LC0130-8AD	68
		2750				190					500		293.5	3.1		2LC0130-8AD	103	
285	4300	2750	48	110	48	110	285	164	175	110	190	4.5	500	304.5	0.13	3.1	2LC0131-0AD	115
		2150									236		630	350.5		8.5	2LC0131-0AD	171
320	5500	2150	55	125	55	125	320	180	192	125	236	4.5	630	365.5	0.23	8.6	2LC0131-1AD	185
		1900									265		710	394.5		14.8	2LC0131-1AD	230
360	7800	2150	65	135	65	135	360	200	210	140	236	4.5	630	380.5	0.41	8.9	2LC0131-2AD	210
		1900									265		710	409.5		15.1	2LC0131-2AD	255

Configurable variants ¹⁾

- ØD1 Without finished bore
With finished bore
- ØD2 Without finished bore
With finished bore

Note

- For dimensions U1 and P, see type RWS on Page 8/10.
- Weight and mass moments of inertia apply to maximum bore diameters.
- The article numbers apply to standard buffers of NBR material in the 80 ShoreA variant; the article number for alternative buffer types is available on request.

Ordering example

- RUPEX RBS coupling, size 252
- Part 1: Bore 48H7 mm, keyway to DIN 6885-1 and set screw
- Part 3: 500 x 190, bore 42H7 mm, keyway to DIN 6885-1 P9 and set screw
- Coupling micro-balanced G6.3 at 1500 rpm in accordance with half parallel key standard

Article no.: 2LC0130-8AD99-0FA0-Z L1B+M0X+W02+Y95
Plain text to Y95: G 6.3 N, n = 1500 rpm

¹⁾ To identify complete item numbers specifying the available finish boring options and – if necessary – further order options, please use our configurators on flender.com.

➤ For online configuration on flender.com, click on the item no.

SPARE AND WEAR PARTS

Buffers and pins

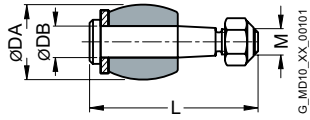

Sizes 105 to 400

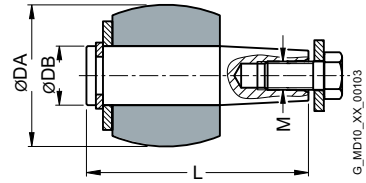

Sizes 710 to 2000

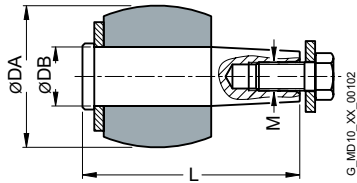

Sizes 450 to 630

Size	Marking	Number per set	Dimensions				Article No. for a set of buffers (Buffer Perbunan 80ShoreA)	Weight <i>m</i> kg	Article No. for a set of pins (Pin complete, incl. fasteners)	Weight <i>m</i> kg
			DA mm	DB mm	L mm	M				
105	105	8	20	8	45	M6	2LC0130-1WA00-0AA0	0.043	2LC0130-1WB00-0AA0	0.14
125	125	8	24	10	53.5	M8	2LC0130-2WA00-0AA0	0.098	2LC0130-2WB00-0AA0	0.28
144 ¹⁾	125	10	24	10	53.5 59.5	M8	2LC0130-3WA00-0AA0	0.12	2LC0130-3WB00-0AA0 ASE36074885	0.35 0.4
162 ¹⁾	162	9	30	12	64.5 67.5	M10	2LC0130-4WA00-0AA0	0.17	2LC0130-4WB00-0AA0 ASE36074964	0.57 0.6
178 ¹⁾	162	10	30	12	64.5 67.5	M10	2LC0130-5WA00-0AA0	0.19	2LC0130-5WB00-0AA0 ASE36075371	0.65 0.67
198 ¹⁾	162	12	30	12	64.5 67.5	M10	2LC0130-6WA00-0AA0	0.23	2LC0130-6WB00-0AA0 ASE36075396	0.76 0.8
228	228	11	40	16	79	M12	2LC0130-7WA00-0AA0	0.42	2LC0130-7WB00-0AA0	1.4
252	228	12	40	16	79	M12	2LC0130-8WA00-0AA0	0.45	2LC0130-8WB00-0AA0	1.5
285	285	11	48	20	98	M16	2LC0131-0WA00-0AA0	0.81	2LC0131-0WB00-0AA0	2.5
320	285	12	48	20	98	M16	2LC0131-1WA00-0AA0	0.88	2LC0131-1WB00-0AA0	2.8
360	360	10	64	25	123	M18	2LC0131-2WA00-0AA0	1.6	2LC0131-2WB00-0AA0	4.4
400	360	14	64	25	123	M18	2LC0131-3WA00-0AA0	2.2	2LC0131-3WB00-0AA0	6.1
450	450	12	78	32	123	M16	2LC0131-4WA00-0AA0	3.5	2LC0131-4WB00-0AA0	11
500	450	14	78	32	123	M16	2LC0131-5WA00-0AA0	4	2LC0131-5WB00-0AA0	13
560	560	12	101	42	158	M20	2LC0131-6WA00-0AA0	7.1	2LC0131-6WB00-0AA0	25
630	560	14	101	42	158	M20	2LC0131-7WA00-0AA0	8.3	2LC0131-7WB00-0AA0	29
710	710	14	120	50	185.5	M24	2LC0131-8WA00-0AA0	14	2LC0131-8WB00-0AA0	49
800	710	16	120	50	185.5	M24	2LC0132-0WA00-0AA0	16	2LC0132-0WB00-0AA0	56
900	900	16	136	55	207.5	M24	2LC0132-1WA00-0AA0	24	2LC0132-1WB00-0AA0	71
1000	900	18	136	55	207.5	M24	2LC0132-2WA00-0AA0	27	2LC0132-2WB00-0AA0	80
1120	1120	18	155	60	232.5	M30	2LC0132-3WA00-0AA0	41	2LC0132-3WB00-0AA0	110
1250	1120	20	155	60	232.5	M30	2LC0132-4WA00-0AA0	45	2LC0132-4WB00-0AA0	125
1400	1400	20	175	70	274	M30	2LC0132-5WA00-0AA0	65	2LC0132-5WB00-0AA0	185
1600	1400	24	175	70	274	M30	2LC0132-6WA00-0AA0	78	2LC0132-6WB00-0AA0	225
1800	1800	22	200	80	327	M36	2LC0132-7WA00-0AA0	115	2LC0132-7WB00-0AA0	320
2000	1800	26	200	80	327	M36	2LC0132-8WA00-0AA0	135	2LC0132-8WB00-0AA0	380

Note

- The buffers of RUPEX couplings are wear parts.
The service life depends on the operating conditions.

¹⁾ For types RWB/RBS with brake disk BB = 30 only



FLEXIBLE COUPLINGS N-BIPEX SERIES



General	9/3
Benefits	9/3
Application	9/4
Function	9/4
Design and configurations	9/5
Technical specifications	9/7
Assignment of N-BIPEX sizes to output PM of IEC standard motors	9/9
Type BWN	9/10
Type BWT – Variant A	9/11
Type BWT – Variant B	9/12
Type BWT – Variant AB	9/13
Type BNT	9/14
Spare and wear parts	9/15



N-BIPEX

FLENDER

GENERAL

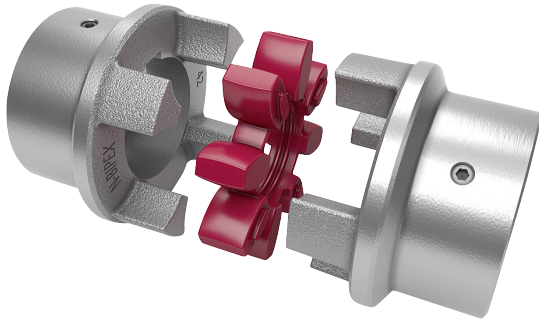

Coupling suitable for use in potentially explosive atmospheres.

Complies with the current ATEX Directive for:

CE  II 2G Ex h IIB T6 ... T4 Gb X

 II 2D Ex h IIIC T85 °C ... 120 °C Db X

 I M2 Ex h Mb X

N-BIPEX couplings are torsionally flexible and are outstanding for their particularly compact design and low weight.

N-BIPEX couplings are used in many areas of mechanical engineering.

Their main area of use is in electric motor drives which are well aligned and have uniform torque loads, such as in hydraulic applications and in combinations with geared motors.

Benefits

N-BIPEX couplings are suitable for horizontal, vertical and freely selectable mounting positions. They are able to absorb axial, radial and angular misalignment.

N-BIPEX couplings consist of two identical hub parts which can be arranged as required on the shaft extensions to be connected. N-BIPEX couplings transmit the torque positively and are thus fail-safe. The curved design of the cast cams ensures that the N-BIPEX couplings have a perfect pressure distribution and this increases the elastomer lifetime.

The flexible cam rings responsible for torque transmission and misalignment compensation are available in different Shore hardnesses. As a result of the good damping capability and by selecting the suitable stiffness, torque shock loads can thus be absorbed and the torsional vibration behavior of the drive can be positively influenced.

Different cam ring versions and ready-to-install hub parts are available from stock.

GENERAL

Application

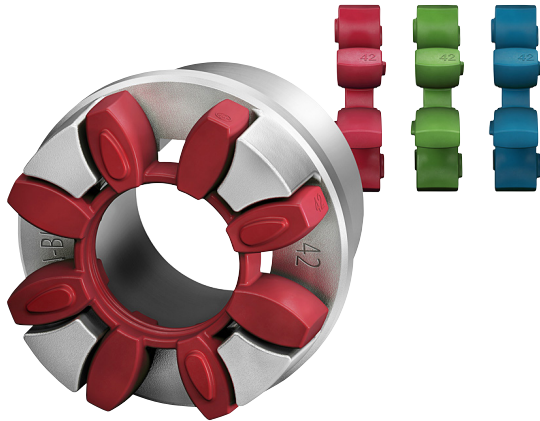

9

The N-BIPEX coupling is available as a catalog standard in 10 sizes with rated torques of between 12 Nm and 4650 Nm and is made of high-grade spheroidal graphite cast iron.

The extremely high-performance cam ring materials are available from stock in three different Shore hardnesses with the following colors:

- 92 ShoreA – red
- 95 ShoreA – green
- 64 ShoreD – blue

An additional size marking has been provided on the outer surface of the cam ring to be able to determine the size of the N-BIPEX even when it is in the assembled state without having to use any additional aids.

The coupling is suitable for use at ambient temperatures between -50 °C and +100 °C without any restrictions on the rated torque as a result of temperature factors.

Function

The torque is transmitted to the hub at the drive end via the shaft-hub connection, which is mostly designed as a keyway connection, and is transmitted to the hub on the output side via the cam ring. This hub then further transmits the torque to the driven machine or a gear unit placed in between.

The special cam ring design helps to keep the compression-loaded cam ring elements in their defined position under all operating conditions and to keep them evenly loaded. This results in a long lifetime of the flexible elements.

A long lifetime is also guaranteed by the hub parts which ensure maximum operational reliability even under harsh operating conditions.

Design and configurations

The N-BIPEX coupling of type BWN comprises two identical hub parts connected by a cam ring of elastomer material.

The hubs are connected to the respective shafts via finished bores with parallel keyway connection or Taper clamping bushes. N-BIPEX couplings are positive-locking and torsionally flexible thanks to the thermoplastic polyurethane cam ring.

Coupling materials

Hubs:

- EN-GJS-400-15

Cam ring:

- TPU 92 ShoreA
-50 °C to +100 °C without any restrictions
- TPU 95 ShoreA
-50 °C to +100 °C without any restrictions
- TPU 64 ShoreD
-50 °C to +100 °C without any restrictions.

The coupling comprises the following:

- Cam ring
- 2 hub parts with identical cams.

The hub parts are designed with a bore and keyway to DIN 6885-1 or with a taper bore for mounting a Taper clamping bush.

Fitting the clamping bush connects the hub firmly to the machine shaft.

In the case of part 4 the Taper clamping bush is inserted from the machine housing side. If there is insufficient space, the Taper clamping bush cannot be fitted from this side. Besides space for fitting the Taper clamping bush, space for the fitting tool (offset screwdriver) must be taken into consideration. In the case of part 3, the Taper clamping bush is screwed in from the shaft end face side. The hub must be fitted before the machines to be connected are pushed together.

N-BIPEX coupling types

Type	Description
BWN	Coupling as a shaft-shaft connection with drilled and grooved hubs
BWT	Coupling as a shaft-shaft connection with Taper clamping bushes
BNT	Coupling as a shaft-shaft connection with drilled and grooved hubs and a Taper clamping bush

GENERAL

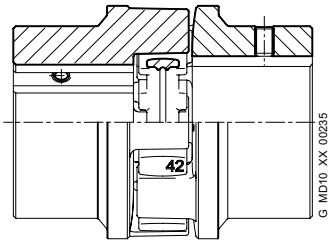

Type BWN

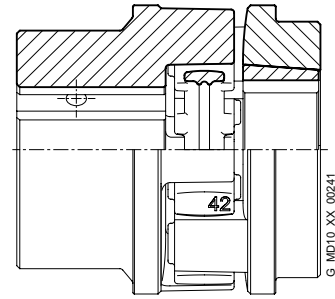

Type BNT

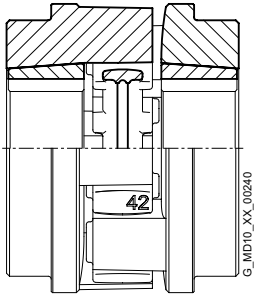

Type BWT

9

Size	Un-drilled	Preferred bores part 1/2 from stock with cylindrical finished bores \emptyset in mm H7, parallel keyway according to DIN 6885-1 JS9																																			
		10	11	12	14	15	16	17	18	19	20	22	24	25	28	30	32	35	38	40	42	45	48	50	55	60	65	70	75	80	85	90	100	110	120		
19																																					
24																																					
28																																					
38																																					
42																																					
48																																					
55																																					
65																																					
75																																					
90																																					

Preferred bores

Technical specifications

Cam rings									
Size	Rated torque	Maximum torque	Fatigue torque	Maximum speed	Damping coefficient ψ	Torsional stiffness at 50 % capacity utilization	Permitted shaft misalignment at ¹⁾		
	T_{KN} Nm	T_{Kmax} Nm	T_{KW} Nm	$V \leq 45$ m/s n_{max} rpm			$C_{Tdyn 50\%}$ Nm/rad	< 10 Hz ΔK_a mm	n = 1500 rpm ΔK_r mm
Cam rings of polyurethane 92 ShoreA (standard)									
19	12	36	2	19500	1.4	530	0.3	0.17	0.5
24	45	135	7	14500	1.4	1790	0.4	0.23	0.5
28	95	285	14	12500	1.4	3060	0.5	0.25	0.5
38	190	570	29	10000	1.4	6500	0.6	0.29	0.5
42	265	795	40	8500	1.4	8200	0.7	0.34	0.5
48	330	990	50	7500	1.4	10000	0.8	0.38	0.5
55	460	1380	70	6500	1.4	14500	0.9	0.4	0.5
65	670	2010	100	6000	1.4	25600	1	0.45	0.5
75	1400	4200	210	5000	1.4	37400	1.2	0.52	0.5
90	2500	7500	375	4000	1.4	62700	1.4	0.6	0.5
Cam rings of polyurethane 95 ShoreA (ordering option -Z and order code K01)									
19	18	54	3	19500	1.4	1130	0.27	0.15	0.4
24	65	195	10	14500	1.4	4240	0.36	0.21	0.4
28	160	480	25	12500	1.4	8050	0.45	0.23	0.4
38	325	975	50	10000	1.4	14100	0.54	0.26	0.4
42	450	1350	70	8500	1.4	16200	0.63	0.31	0.4
48	550	1650	85	7500	1.4	23300	0.72	0.34	0.4
55	700	2100	105	6500	1.4	28500	0.81	0.36	0.4
65	1000	3000	150	6000	1.4	35000	0.9	0.41	0.4
75	2000	6000	300	5000	1.4	66300	1.08	0.47	0.4
90	3700	11100	555	4000	1.4	105000	1.26	0.54	0.4
Cam rings of polyurethane 64 ShoreD (ordering option -Z and order code K04)									
19	25	75	5	19500	1.4	2010	0.24	0.14	0.3
24	90	270	15	14500	1.4	7680	0.32	0.18	0.3
28	200	600	30	12500	1.4	12200	0.4	0.2	0.3
38	405	1215	60	10000	1.4	25100	0.48	0.23	0.3
42	560	1680	84	8500	1.4	32000	0.56	0.27	0.3
48	700	2100	105	7500	1.4	41200	0.64	0.3	0.3
55	925	2775	140	6500	1.4	52600	0.72	0.32	0.3
65	1200	3600	180	6000	1.4	86700	0.8	0.36	0.3
75	2600	7800	390	5000	1.4	143000	0.96	0.42	0.3
90	4650	13950	700	4000	1.4	234000	1.12	0.48	0.3

¹⁾ The maximum speed must be observed. For further information on the allowable shaft misalignment, please refer to the operating instructions.

GENERAL

Torsional stiffness and damping

The values stated in the above table apply to a capacity utilization of 50 %, an excitation amplitude of 10 % T_{KN} with frequency 10 Hz and an ambient temperature of 20 °C. The dynamic torsional stiffness (C_{Tdyn}) is load-dependent and increases in proportion to capacity utilization. The following table shows the correction factors for different nominal load.

$$C_{Tdyn} = C_{Tdyn} 50 \% \cdot FKC$$

	Load T_N / T_{KN}						
	20%	40%	50%	60%	70%	80%	100%
Correction factor FKC							
92/95 ShoreA and	0.56	0.85	1	1.17	1.35	1.53	1.92
64 ShoreD							

Furthermore, torsional stiffness and damping depend on the ambient temperature, the frequency and the amplitude of the torsional vibration excitation. More precise torsional stiffness and damping parameters on request.

With flexible couplings the manufacturing process of the rubber elements and their aging primarily influence the stiffness value C_{Tdyn} . For this reason calculation must be made with a tolerance for the dynamic stiffness of $\pm 20\%$. The specified damping coefficient Ψ is a minimum value with the result that the damping performance of the coupling corresponds at least to the specified value.

Permitted shaft misalignment

The permitted shaft misalignment depends on the operating speed. As the speed increases, lower shaft misalignment values are permitted. The correction factors for different speeds are specified in the following table. The maximum speed depending on the respective coupling size and type must be observed!

$$\Delta K_{perm} = \Delta K_{1500} \cdot FKV$$

	Speed in rpm			
	500	1000	1500	3000
Correction factor FKV	1.20	1.10	1.00	0.70

The axial misalignment may occur dynamically at frequencies up to 10 Hz.

For fitting, the maximum gap dimension of $S2_{max.} = S2 + \Delta S2$ and the minimum gap dimension of $S2_{min.} = S2 - \Delta S2$ are permitted.

The shaft misalignments ΔK_a , ΔK_r and ΔK_w may occur simultaneously (see Page E/8).

Assignment of N-BIPEX sizes to output PM of IEC standard motors ¹⁾

Three-phase motor Size	Motor output at ≈ 3000 min ⁻¹		N-BIPEX coupling Size	Motor output at ≈ 1500 min ⁻¹		N-BIPEX coupling Size	Motor output at ≈ 1000 min ⁻¹		N-BIPEX coupling Size	Motor output at ≈ 750 min ⁻¹		N-BIPEX coupling Size	DE shaft end D x E acc. to IEC	
	P _M kW	T Nm		P _M kW	T Nm		P _M kW	T Nm		P _M kW	T Nm		D mm	E mm
80	0.75	2.5	19	0.55	3.7	19	0.37	3.9	19	0.18	2.5	19	19	40
	1.1	3.7	19	0.75	5.1	19	0.55	5.8	19	0.25	3.5	19		
90S	1.5	5	19	1.1	7.5	19	0.75	8	19	0.37	5.3	19	19	40
90L	2.2	7.4	19	1.5	10	24	1.1	12	24	0.55	7.9	24	19	40
													24	50
100L	3	9.8	24	2.2	15	24	1.5	15	24	0.75	11	24	28	60
				3	20	24				1.1	16	24		
112M	4	13	24	4	27	24	2.2	22	24	1.5	21	24	28	60
132S	5.5	18	28	5.5	36	28	3	30	28	2.2	30	28	38	80
	7.5	25	28											
132M				7.5	49	28	4	40	28	3	40	28	38	80
							5.5	55	28					
160M	11	36	38	11	72	38	7.5	75	38	4	54	38	42	110
	15	49	38							5.5	74	38		
160L	18.5	60	38	15	98	38	11	109	38	7.5	100	38	42	110
180M	22	71	38	18.5	121	38							48	110
180L				22	144	38	15	148	42	11	145	42	48	110
200L	30	97	42	30	196	42	18.5	181	42	15	198	42	55	110
	37	120	42				22	215	42					
225S				37	240	48				18.5	244	48	60	140
225M	45	145	42										55	110
				45	292	55	30	293	55	22	290	55	60	140
250M	55	177	48										60	140
				55	356	55	37	361	55	30	392	65	65	140
280S	75	241	55										65	140
				75	484	65	45	438	65	37	483	65	75	140
280M	90	289	55										65	140
				90	581	75	55	535	75	45	587	75	75	140
315S	110	353	55										65	140
				110	707	75	75	727	75	55	712	75	80	170
315M	132	423	65										65	140
				132	849	75	90	873	75	75	971	75	80	170
315L	160	513	65										65	140
	200	641	75											
				160	1030	75	110	1070	75	90	1170	90	80	170
				200	1290	90	132	1280	90	110	1420	90		
315	250	802	75										65	140
	315	1010	90											
355				250	1600	90	200	1930	90				85	170
	355	1140	90										75	140
	400	1280	90										75	140
	500	1600	90										75	140
400	560	1790	90									80	170	

¹⁾ The assignment applies for an service factor of 1.25 and the use of a standard cam ring (92 ShoreA).

TYPE BWN

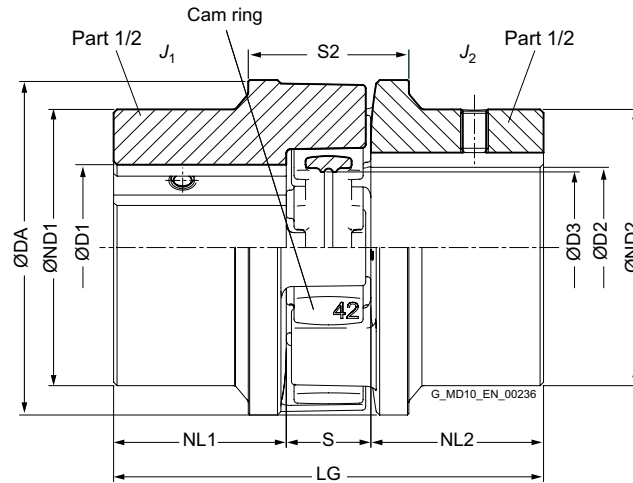

Size	Rated torque			Speed n_{Kmax} rpm	Dimensions in mm										Mass moment of inertia J_1/J_2 kgm ²	Article no. ¹⁾	Weight m kg
	T_{KN}		64ShoreD Nm		D1/D2 Keyway DIN 6885 min.	DA	ND1/ ND2	NL1/ NL2	D3	S	S2	ΔS2	LG				
	92 ShoreA Nm	95 ShoreA Nm												max.			
19	12	18	25	19500	0	25	42	38	25	17	16	31	1	66	0.000045	2LC0160-0AA	0.3
24	45	65	90	14500	0	35	57	50	30	25	18	37	1.5	78	0.00015	2LC0160-1AA	0.6
28	95	160	200	12500	0	40	67	58	35	28	20	41	1	90	0.00033	2LC0160-2AA	1
38	190	325	405	10000	0	48	82	68	45	36	24	45	1.5	114	0.0009	2LC0160-3AA	1.7
42	265	450	560	8500	0	55	97	80	50	43	26	48	1.5	126	0.0019	2LC0160-4AA	2.6
48	330	550	700	7500	0	62	107	90	56	48	28	50	2	140	0.0031	2LC0160-5AA	3.6
55	460	700	925	6500	0	75	123	105	65	57	30	60	2	160	0.006	2LC0160-6AA	5.2
65	670	1000	1200	6000	0	82	138	115	75	64	35	65	2.5	185	0.011	2LC0160-7AA	7.5
75	1400	2000	2600	5000	0	96	163	135	85	76	40	75	2.5	210	0.023	2LC0160-8AA	11.5
90	2500	3700	4650	4000	0	120	203	170	100	95	45	85	3	245	0.065	2LC0161-0AA	21.4

Configurable variants ¹⁾

- ØD1 Without finished bore
With finished bore
- ØD2 Without finished bore
With finished bore
- Cam ring hardness **92 ShoreA**
95 ShoreA
64 ShoreD

Notes

- Mass moments of inertia apply to a coupling half with maximum bore diameter.
- Weights apply to a whole coupling in the version with maximum bore.

Ordering example

- N-BIPEX coupling BWN, size 42
- Part 1/2: Bore D1 42 H7 mm, with keyway to DIN 6885-1 and set screw
- Part 1/2: Bore D2 32 H7 mm, with keyway to DIN 6885-1 and set screw
- Cam ring hardness 92 ShoreA

Article no.: 2LC0160-4AA99-0AA0-Z L0X+M0T

¹⁾ To identify complete item numbers specifying the available finish boring options and – if necessary – further order options, please use our configurators on flender.com.

↗ For online configuration on flender.com, click on the item no.

TYPE BWT

Variant A

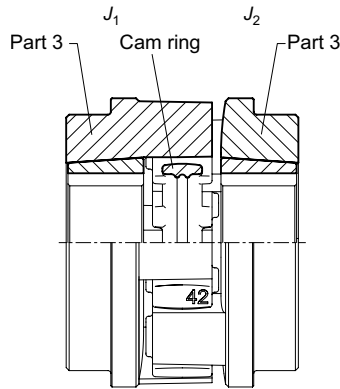

Variant A

Size	Taper Clamping Bush Size	Rated torque		Speed n_{Kmax} rpm	Dimensions in mm										Mass moment of inertia J_1/J_2 kgm ²	Article no. ¹⁾ Type A	Weight <i>m</i> kg
		T_{KN}			D1/D2 Keyway DIN 6885	DA	ND1/ ND2	NL1/ NL2	D3	S	S2	ΔS2	LG				
		92 ShoreA Nm	95 ShoreA Nm											min.			
24	1008	45	65	14500	10	25	57	54	23	25	18	37	1.5	64	0.00015	2LC0160-1AB	0.6
28	1108	95	160	12500	10	28	67	58	23	28	20	41	1	66	0.00025	2LC0160-2AB	0.8
38	1108	190	325	10000	10	28	82	58	23	36	24	45	1.5	70	0.0005	2LC0160-3AB	1.2
42	1610	265	450	8500	14	42	97	86	26	43	26	48	1.5	78	0.0013	2LC0160-4AB	1.8
48	1615	330	550	7500	14	42	107	80	39	48	28	50	2	106	0.002	2LC0160-5AB	2.6
55	2012	460	700	6500	14	50	123	100	33	57	30	60	2	96	0.004	2LC0160-6AB	3.5
65	2012	670	1000	6000	14	50	138	100	33	64	35	65	2.5	101	0.006	2LC0160-7AB	4.5
	2517 ²⁾				55	60								118			46
75	2517	1400	2000	5000	16	60	163	118	46	76	40	75	2.5	132	0.015	2LC0160-8AB	7.7
	3020 ²⁾				65	75								142			52
90	3020	2500	3700	4000	25	75	205	142	52	95	45	85	3	149	0.037	2LC0161-0AB	12.9
	3535 ²⁾				80	90								170			90

Configurable variants ¹⁾

- ØD1 Without Taper clamping bush
With Taper clamping bush
- ØD2 Without Taper clamping bush
With Taper clamping bush
- Cam ring hardness **92 ShoreA**
95 ShoreA

Notes

- Mass moments of inertia apply to a coupling half without Taper clamping bush.
- Weights apply to a whole coupling in the version without Taper clamping bush.
- T_{Kmax} for the 95 ShoreA cam ring is limited to $2 \times T_{KN}$ for types BWT and BNT contrary to the table on Page 9/7. When using the 64 ShoreD cam ring, the same torque values apply as for the 95 ShoreA cam ring.

Ordering example

- N-BIPEX BWT coupling, size 42, variant A
- Part 3: With Taper clamping bushes, size 1610, bore D1 38 H7 mm, with keyway to DIN 6885-1
- Part 4: With Taper clamping bushes, size 1610, bore D2 32 H7 mm, with keyway to DIN 6885-1
- Cam ring hardness 92 ShoreA

Article no.: 2LC0160-4AB99-0AA0-Z L0V+M0T

¹⁾ To identify complete item numbers specifying the available finish boring options and – if necessary – further order options, please use our configurators on flender.com.

²⁾ Taper clamping bush version only possible in part 4.

↗ For online configuration on flender.com, click on the item no.

TYPE BWT

Variant B

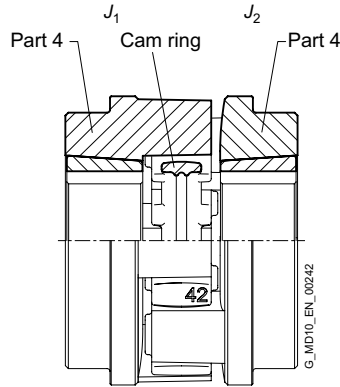

Variant B

Size	Taper Clamping Bush Size	Rated torque		Speed n_{Kmax} rpm	Dimensions in mm										Mass moment of inertia J_1/J_2 kgm ²	Article no. ¹⁾ Type B	Weight m kg
		T_{KN}			D1/D2 Keyway DIN 6885	DA	ND1/ ND2	NL1/ NL2	D3	S	S2	ΔS2	LG				
		Nm	Nm											min.			
24	1008	45	65	14500	10	25	57	54	23	25	18	37	1.5	64	0.00015	2LC0160-1AC	0.6
28	1108	95	160	12500	10	28	67	58	23	28	20	41	1	66	0.00025	2LC0160-2AC	0.8
38	1108	190	325	10000	10	28	82	58	23	36	24	45	1.5	70	0.0005	2LC0160-3AC	1.2
42	1610	265	450	8500	14	42	97	86	26	43	26	48	1.5	78	0.0013	2LC0160-4AC	1.8
48	1615	330	550	7500	14	42	107	80	39	48	28	50	2	106	0.002	2LC0160-5AC	2.6
55	2012	460	700	6500	14	50	123	100	33	57	30	60	2	96	0.004	2LC0160-6AC	3.5
65	2012	670	1000	6000	14	50	138	100	33	64	35	65	2.5	101	0.006	2LC0160-7AC	4.5
	55				60	118								46	127		0.008
75	2517	1400	2000	5000	16	60	163	118	46	76	40	75	2.5	132	0.015	2LC0160-8AC	7.7
	3020 ²⁾				65	75								142	52		144
90	3020	2500	3700	4000	25	75	205	142	52	95	45	85	3	149	0.037	2LC0161-0AC	12.9
	3535 ²⁾				80	90								170	90		225

Configurable variants ¹⁾

- ØD1 Without Taper clamping bush
With Taper clamping bush
- ØD2 Without Taper clamping bush
With Taper clamping bush
- Cam ring hardness **92 ShoreA**
95 ShoreA

Notes

- Mass moments of inertia apply to a coupling half without Taper clamping bush.
- Weights apply to a whole coupling in the version without taper clamping bush.
- T_{Kmax} for the 95 ShoreA cam ring is limited to $2 \times T_{KN}$ for types BWT and BNT contrary to the table on Page 9/7. When using the 64 ShoreD cam ring, the same torque values apply as for the 95 ShoreA cam ring.

Ordering example

- N-BIPEX BWT coupling, size 42, variant B
- Part 3: With Taper clamping bushes, size 1610, bore D1 38 H7 mm, with keyway to DIN 6885-1
- Part 4: With Taper clamping bushes, size 1610, bore D2 32 H7 mm, with keyway to DIN 6885-1
- Cam ring hardness 92 ShoreA

Article no.: 2LC0160-4AC99-0AA0-Z L0V+M0T

¹⁾ To identify complete item numbers specifying the available finish boring options and – if necessary – further order options, please use our configurators on flender.com.

²⁾ Taper clamping bush version only possible in part 4.

↗ For online configuration on flender.com, click on the item no.

TYPE BWT

Variant AB

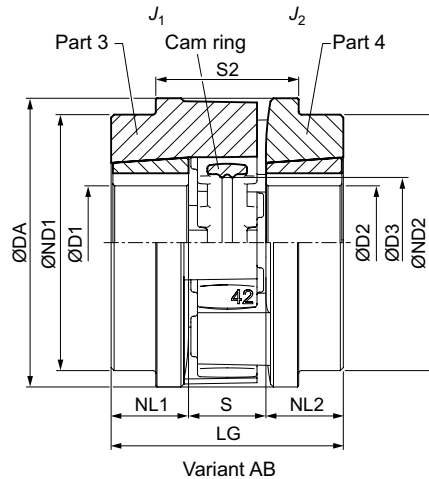

Size	Taper Clamping Bush Size	Rated torque		Speed n_{Kmax} rpm	Dimensions in mm										Mass moment of inertia J_1/J_2 kgm ²	Article no. ¹⁾ Type AB	Weight m kg
		T_{KN}			D1/D2 Keyway DIN 6885	DA	ND1/ ND2	NL1/ NL2	D3	S	S2	$\Delta S2$	LG				
		92 ShoreA Nm	95 ShoreA Nm											min.			
24	1008	45	65	14500	10	25	57	54	23	25	18	37	1.5	64	0.00015	2LC0160-1AD	0.6
28	1108	95	160	12500	10	28	67	58	23	28	20	41	1	66	0.00025	2LC0160-2AD	0.8
38	1108	190	325	10000	10	28	82	58	23	36	24	45	1.5	70	0.0005	2LC0160-3AD	1.2
42	1610	265	450	8500	14	42	97	86	26	43	26	48	1.5	78	0.0013	2LC0160-4AD	1.8
48	1615	330	550	7500	14	42	107	80	39	48	28	50	2	106	0.002	2LC0160-5AD	2.6
55	2012	460	700	6500	14	50	123	100	33	57	30	60	2	96	0.004	2LC0160-6AD	3.5
65	2012	670	1000	6000	14	50	138	100	33	64	35	65	2.5	101	0.006	2LC0160-7AD	4.5
	2517 ²⁾				55	60								118			46
75	2517	1400	2000	5000	16	60	163	118	46	76	40	75	2.5	132	0.015	2LC0160-8AD	7.7
	3020 ²⁾				65	75								142			52
90	3020	2500	3700	4000	25	75	205	142	52	95	45	85	3	149	0.037	2LC0161-0AD	12.9
	3535 ²⁾				80	90								170			90

Configurable variants ¹⁾

- ØD1 Without Taper clamping bush
With Taper clamping bush
- ØD2 Without Taper clamping bush
With Taper clamping bush
- Cam ring hardness **92 ShoreA**
95 ShoreA

Notes

- Mass moments of inertia apply to a coupling half without Taper clamping bush.
- Weights apply to a whole coupling in the version without taper clamping bush.
- T_{Kmax} for the 95 ShoreA cam ring is limited to $2 \times T_{KN}$ for types BWT and BNT contrary to the table on Page 9/7. When using the 64 ShoreD cam ring, the same torque values apply as for the 95 ShoreA cam ring.

Ordering example

- N-BIPEX BWT coupling, size 42, variant AB
- Part 3: With Taper clamping bushes, size 1610, bore D1 38 H7 mm, with keyway to DIN 6885-1
- Part 4: With Taper clamping bushes, size 1610, bore D2 32 H7 mm, with keyway to DIN 6885-1
- Cam ring hardness 92 ShoreA

Article no.: 2LC0160-4AD99-0AA0-Z L0V+M0T

¹⁾ To identify complete item numbers specifying the available finish boring options and – if necessary – further order options, please use our configurators on flender.com.

²⁾ Taper clamping bush version only possible in part 4.

➤ For online configuration on flender.com, click on the item no.

TYPE BNT

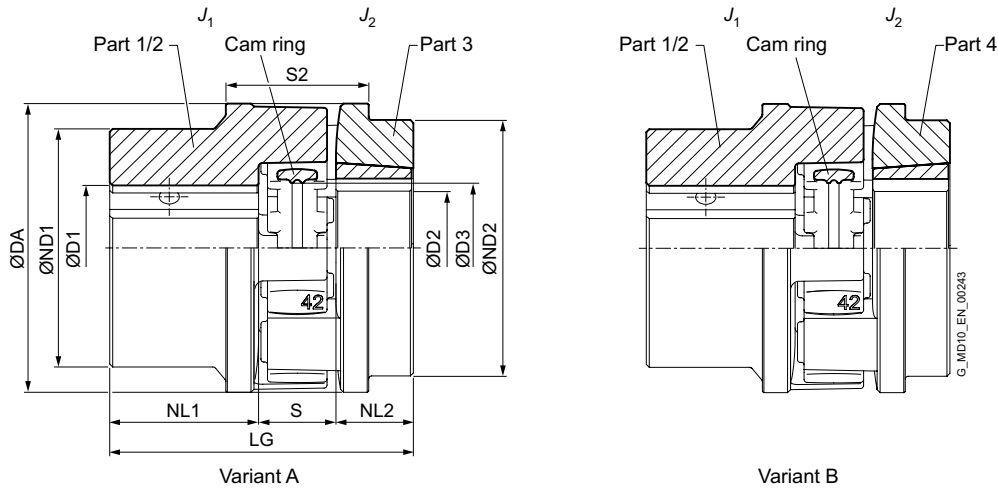

9

Size	Taper Clamping Bush Size	Rated torque		Speed n_{Kmax} rpm	Dimensions in mm														Mass moment of inertia		Article no. ¹⁾		Weight m kg
		T_{KN}	T_{KN}		D1 Keyway DIN 6885 min. max.	D2 Keyway DIN 6885 min. max.	DA	ND1	ND2	NL1	NL2	D3	S	S2	$\Delta S2$	LG	J_1 kgm ²	J_2 kgm ²	Type	Type			
		92 ShoreA Nm	95 ShoreA Nm																A	B			
24	1008	45	65	14500	0	35	10	25	57	50	54	30	23	25	18	37	1.5	71	0.00015	0.00015	2LC0160-1AE	2LC0160-1AF	0.6
28	1108	95	160	12500	0	40	10	28	67	58	58	35	23	28	20	41	1	78	0.0003	0.0002	2LC0160-2AE	2LC0160-2AF	0.8
38	1108	190	325	10000	0	48	10	28	82	68	58	45	23	36	24	45	1.5	92	0.0009	0.0005	2LC0160-3AE	2LC0160-3AF	1.4
42	1610	265	450	8500	0	55	14	42	97	80	86	50	26	43	26	48	1.5	102	0.002	0.0013	2LC0160-4AE	2LC0160-4AF	2.3
48	1615	330	550	7500	0	62	14	42	107	90	80	56	39	48	28	50	2	123	0.003	0.002	2LC0160-5AE	2LC0160-5AF	3.2
55	2012	460	700	6500	0	75	14	50	123	105	100	65	33	57	30	60	2	128	0.006	0.004	2LC0160-6AE	2LC0160-6AF	4.4
65	2012	670	1000	6000	0	82	14	50	138	115	100	75	33	64	35	65	2.5	143	0.011	0.006	2LC0160-7AE	2LC0160-7AF	6
	2517 ²⁾																				156	0.011	0.008
75	2517	1400	2000	5000	0	96	55	60	163	135	118	85	46	76	40	75	2.5	171	0.023	0.014	2LC0160-8AE	2LC0160-8AF	9.4
	3020 ²⁾																				177	0.023	0.016
90	3020	2500	3700	4000	0	120	25	75	205	170	142	100	52	95	45	85	3	197	0.065	0.036	2LC0161-0AE	2LC0161-0AF	17.2
	3535 ²⁾																				235	0.065	0.06

Configurable variants ¹⁾

• Type	A B
• ØD1	Without Taper clamping bush With Taper clamping bush
• ØD2	Without Taper clamping bush With Taper clamping bush
• Cam ring hardness	92 ShoreA 95 ShoreA

Notes

- Mass moments of inertia apply to a coupling half with maximum bore diameter and without Taper clamping bush.
- Weights apply to a whole coupling in the version without taper clamping bush.
- T_{Kmax} for the 95 ShoreA cam ring is limited to $2 \times T_{KN}$ for types BWT and BNT contrary to the table on Page 9/7. When using the 64 ShoreD cam ring, the same torque values apply as for the 95 ShoreA cam ring.

Ordering example

- N-BIPEX BNT coupling, size 42, variant B
- Part 1/2: Bore D1 42 H7 mm, with keyway to DIN 6885-1 and set screw
- Part 4: With Taper clamping bushes, size 1610, bore D2 32 H7 mm, with keyway to DIN 6885-1
- Cam ring hardness 92 ShoreA

Article no.: 2LC0160-4AF99-0AA0-Z L0X+M0T

¹⁾ To identify complete item numbers specifying the available finish boring options and – if necessary – further order options, please use our configurators on flender.com.

²⁾ Taper clamping bush version only possible in part 4.

↗ For online configuration on flender.com, click on the item no.

SPARE AND WEAR PARTS

Cam rings of the N-BIPEX coupling

Size	Article no. N-BIPEX cam ring			Weight kg
	92 ShoreA	95 ShoreA	64 ShoreA	
19	2LC0160-0WA00-0AA0	2LC0160-0WA00-0AA0-Z K01	2LC0160-0WA00-0AA0-Z K04	0.006
24	2LC0160-1WA00-0AA0	2LC0160-1WA00-0AA0-Z K01	2LC0160-1WA00-0AA0-Z K04	0.02
28	2LC0160-2WA00-0AA0	2LC0160-2WA00-0AA0-Z K01	2LC0160-2WA00-0AA0-Z K04	0.03
38	2LC0160-3WA00-0AA0	2LC0160-3WA00-0AA0-Z K01	2LC0160-3WA00-0AA0-Z K04	0.04
42	2LC0160-4WA00-0AA0	2LC0160-4WA00-0AA0-Z K01	2LC0160-4WA00-0AA0-Z K04	0.07
48	2LC0160-5WA00-0AA0	2LC0160-5WA00-0AA0-Z K01	2LC0160-5WA00-0AA0-Z K04	0.09
55	2LC0160-6WA00-0AA0	2LC0160-6WA00-0AA0-Z K01	2LC0160-6WA00-0AA0-Z K04	0.1
65	2LC0160-7WA00-0AA0	2LC0160-7WA00-0AA0-Z K01	2LC0160-7WA00-0AA0-Z K04	0.2
75	2LC0160-8WA00-0AA0	2LC0160-8WA00-0AA0-Z K01	2LC0160-8WA00-0AA0-Z K04	0.4
90	2LC0161-0WA00-0AA0	2LC0161-0WA00-0AA0-Z K01	2LC0161-0WA00-0AA0-Z K04	0.6

Note

- The cam rings of the N-BIPEX coupling are wear parts. The service life depends on the operating conditions.

APPENDIX

Fits	A/2
Fitting recommendations	A/2
Deviation table to DIN ISO 286	A/2
Cylindrical shaft ends, extract from DIN 748 Part 1 (long)	A/3
Central holes according to DIN 332 Part 2	A/3
<hr/>	
Parallel key connections to DIN 6885-1	A/4
<hr/>	
Related catalogs	A/6
<hr/>	
Suitable gear solutions	A/9
<hr/>	

FITS

Fitting recommendations

For many applications, the fit assignment m6/H7 is especially suitable.

Description	Application	Shaft tolerance	Bore tolerance	
Sliding fit with parallel key connection not suitable for reversing operation	For steel and cast hubs	j6	H7	
		h6	J7	
Press fit with parallel key connection not suitable for reversing operation	For steel and cast hubs	h6	K7	
		k6	H7	
Interference fit with parallel key connection suitable for reversing operation	For steel and cast hubs	m6	H7	
		n6	H7	
		h6	M7	
		Only for steel hubs	h6	P7
		Preferred for ZAPEX and ARPEX coupling series.	k6	M7
		m6	K7	
		n6	J7	
		p6	H7	
Shrink fit connection without parallel key	Only for steel hubs The permitted hub tension must be urgently checked.	s6	F7	
		u6	H6	
		v6	H6	
		x6	H6	

Deviation table to DIN ISO 286 for above-mentioned fits for bore diameters from 10 mm to 250 mm

Bore diameter above	up to	Deviations in µm							Shaft					
		Bore							h6	j6	k6	m6	n6	p6
		F7	H7	J7	K7	M7	P7							
10	18	+34	+18	+10	+6	0	-11	0	+8	+12	+18	+23	+29	
		+16	0	-8	-12	-18	-29	-11	-3	+1	+7	+12	+18	
18	30	+41	+21	+12	+6	0	-14	0	+9	+15	+21	+28	+35	
		+20	0	-9	-15	-21	-35	-13	-4	+2	+8	+15	+22	
30	50	+50	+25	+14	+7	0	-17	0	+11	+18	+25	+33	+42	
		+25	0	-11	-18	-25	-42	-16	-5	+2	+9	+17	+26	
50	80	+60	+30	+18	+9	0	-21	0	+12	+21	+30	+39	+51	
		+30	0	-12	-21	-30	-51	-19	-7	+2	+11	+20	+32	
80	120	+71	+35	+22	+10	0	-24	0	+13	+25	+35	+45	+59	
		+36	0	-13	-25	-35	-59	-22	-9	+3	+13	+23	+37	
120	180	+83	+40	+26	+12	0	-28	0	+14	+28	+40	+52	+68	
		+43	0	-14	-28	-40	-68	-25	-11	+3	+15	+27	+43	
180	250	+96	+46	+30	+13	0	-33	0	+16	+33	+46	+60	+79	
		+50	0	-16	-33	-46	-79	-29	-13	+4	+17	+31	+50	

A

Cylindrical shaft ends, extract from DIN 748 Part 1 (long)

	Diameter in mm																					
	24	25	28	30	32	35	38	40	42	45	48	50	55	60	65	70	75	80	85	90	95	100
ISO tolerance zone	k6												m6									
End length in mm	50	60	80					110						140				170				210

Central holes according to DIN 332 Part 2

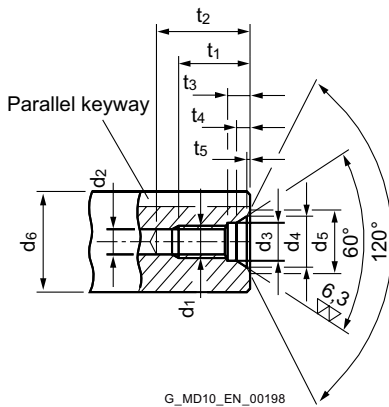

Form DS (with thread) DIN 332/2

Recommended diameter ranges d_6 ¹⁾		DS form dimensions									
above	up to	d_1	d_2 ²⁾	d_3	d_4	d_5	t_1 ₊₂	t_2 _{min.}	t_3 ₊₁	t_4 _{approx.}	t_5 _{approx.}
7	10	M3	2.5	3.2	5.3	5.8	9	12	2.6	1.8	0.2
10	13	M4	3.3	4.3	6.7	7.4	10	14	3.2	2.1	0.3
13	16	M5	4.2	5.3	8.1	8.8	12.5	17	4	2.4	0.3
16	21	M6	5	6.4	9.6	10.5	16	21	5	2.8	0.4
21	24	M8	6.8	8.4	12.2	13.2	19	25	6	3.3	0.4
24	30	M10	8.5	10.5	14.9	16.3	22	30	7.5	3.8	0.6
30	38	M12	10.2	13	18.1	19.8	28	37	9.5	4.4	0.7
38	50	M16	14	17	23	25.3	36	45	12	5.2	1.0
50	85	M20	17.5	21	28.4	31.3	42	53	15	6.4	1.3
85	130	M24	21	25	34.2	38	50	63	18	8	1.6
130	225	M30 ³⁾	26.5	31	40.2	44.6	60	77	22	8	1.9
225	320	M36 ³⁾	32	37	49.7	55	74	93	22	11	2.3
320	500	M42 ³⁾	37.5	43	60.3	66.6	84	105	26	15	2.7

¹⁾ Diameter refers to the finished workpiece

²⁾ Tap hole drill diameter according to DIN 336 Part 1

³⁾ Dimensions not acc. to DIN 332 Part 2

A

PARALLEL KEY CONNECTIONS TO DIN 6885-1

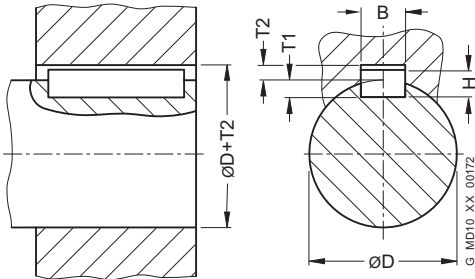

For moderate operating conditions, the hub keyway tolerance JS9 is recommended.

In harsh operating conditions or during reversing operation, the keyway width tolerance P9 must be preferred.

With two parallel keyways, the keyway width tolerance JS9 should be specified in order to simplify the assembly.

The shaft keyway width has to be specified with the tolerance N9.

Diameter above D mm	up to mm	Keyway width B mm	Parallel key height H mm	Shaft keyway depth T1 mm	Hub keyway depth T2 mm	Deviation for shaft and hub keyway depth mm	Deviation table for keyway width B	
							JS9 μm	P9 μm
	10	3	3	1.8	1.4	+0.1	+12.5 -12.5	-6 -31
10	12	4	4	2.5	1.8	+0.1	+15 -15	-12 -42
12	17	5	5	3	2.3	+0.1	+15 -15	-12 -42
17	22	6	6	3.5	2.8	+0.1	+15 -15	-12 -42
22	30	8	7	4	3.3	+0.2	+18 -18	-15 -51
30	38	10	8	5	3.3	+0.2	+18 -18	-15 -51
38	44	12	8	5	3.3	+0.2	+21.5 -21.5	-18 -61
44	50	14	9	5.5	3.8	+0.2	+21.5 -21.5	-18 -61
50	58	16	10	6	4.3	+0.2	+21.5 -21.5	-18 -61
58	65	18	11	7	4.4	+0.2	+21.5 -21.5	-18 -61
65	75	20	12	7.5	4.9	+0.2	+26 -26	-22 -74
75	85	22	14	9	5.4	+0.2	+26 -26	-22 -74
85	95	25	14	9	5.4	+0.2	+26 -26	-22 -74

Diameter		Keyway width B mm	Parallel key height H mm	Shaft keyway depth		Hub keyway depth T2 mm	Deviation for shaft and hub keyway depth mm	Deviation table for keyway width B	
above D mm	up to mm			T1 mm	T2 mm			JS9 µm	P9 µm
95	110	28	16	10	6.4	+0.2	+26 -26	-22 -74	
110	130	32	18	11	7.4	+0.2	+31 -31	-26 -88	
130	150	36	20	12	8.4	+0.3	+31 -31	-26 -88	
150	170	40	22	13	9.4	+0.3	+31 -31	-26 -88	
170	200	45	25	15	10.4	+0.3	+31 -31	-26 -88	
200	230	50	28	17	11.4	+0.3	+31 -31	-26 -88	
230	260	56	32	20	12.4	+0.3	+37 -37	-32 -106	
260	290	63	32	20	12.4	+0.3	+37 -37	-32 -106	
290	330	70	36	22	14.4	+0.3	+37 -37	-32 -106	
330	380	80	40	25	15.4	+0.3	+37 -37	-32 -106	
380	440	90	45	28	17.4	+0.3	+43.5 -43.5	-37 -124	
440	500	100	50	31	19.4	+0.3	+43.5 -43.5	-37 -124	



RELATED CATALOGS

Torsionally Rigid Couplings

FLE 10.1
FLEX-C10001-00-7600



Flexible Couplings

FLE 10.2
FLEX-C10002-00-7600



Highly Flexible Couplings

FLE 10.3
FLEX-C10003-00-7600



Fluid Couplings

FLE 10.4
FLEX-C10004-00-7600



ARPEX

High Performance Couplings
MD 10.2
PDMD-C10146-00



SIPEX and BIPEX-S

Backlash-free couplings
MD 10.3
PDMD-C10145-00



ARPEX

Composite Couplings
MD 10.5
PDMD-C10153-00

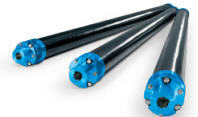

ARPEX

Safety couplings
MD 10.11
PDMD-C10147-00



FLENDER SIP

Standard Industrial Planetary Gear Units

MD 31.1

PDMD-C10154-00

**FLENDER CHG**

Helical Gear Units

MD 20.10

PDMD-C10155-00

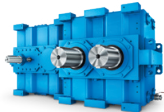
**Gear units**

Fast Track

MD 20.12

PDMD-C10156-00

**Bucket Elevator Drives**

MD 20.2

PDMD-C10157-00

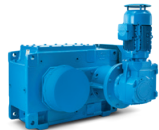
**PLANUREX 2**

Planetary Gear Units

MD 20.3

PDMD-C10158-00

**Paper Machine Drives**

MD 20.5

PDMD-C10159-00

**Conveyor Belt Drives**

MD 20.6

PDMD-C10160-00

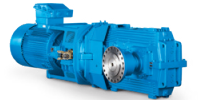
**Marine Reduction Gearboxes**

MD 20.7

PDMD-C10161-00

**DUORED 2**

Helical Gear Units, Load-sharing

MD 20.8

PDMD-C10162-00

**Pinion Drive for Tube Mills**

MD 20.9

PDMD-C10163-00





THE RIGHT GEAR UNIT SOLUTION FOR ANY REQUIREMENT

We provide helical and planetary gear units made up of standard modules or as a complete application solution.

Helical and planetary gear units from Flender are modern drive solutions that satisfy the most varying and extreme demands, day after day and year after year. For decades, plant operators have been achieving high system reliability and low lifecycle costs in every conceivable industry with our helical gear units.

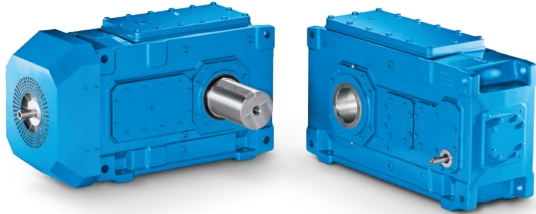

Helical and bevel helical gear units

Flender helical and bevel helical gear units are by far the most comprehensive range of industrial gear units in the world. It ranges from a multi-faceted universal gear unit portfolio and application-specific gear units to customer-specific solutions.

Rated torque: 3,300 Nm ... 1,400,000 Nm

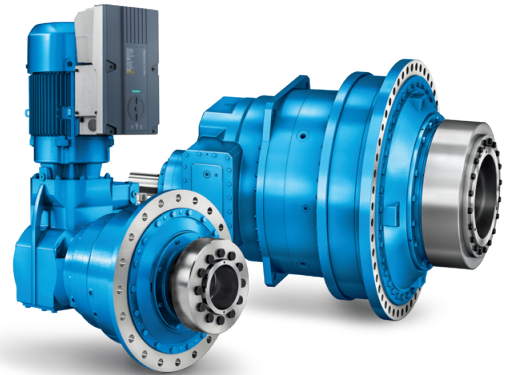

Planetary Gear Units

With Flender planetary gear units, we provide a range of durable, reliable and finely graduated gear unit solutions. The series wins customers over due to its highly integrated planetary geared motor and maximum conformity with all international motor standards. It also brings quality and performance in a good ratio of lifecycle costs to price.

Rated torque: 10,000 Nm ... 5,450,000 Nm

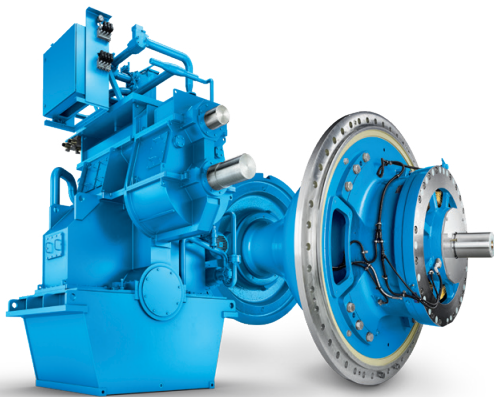

Application-specific gear units

With application-specific gear units, Flender provides by far the most application solutions and thus covers nearly every drive-related need from hundreds of applications in industry and the acquisition of raw materials.

Rated torque: up to 10,000,000 Nm



Customer-specific designs

Our experts are available at any time for special requirements during the development of new products. From designing and simulating complex drive solutions to implementing them, we work together with you to resolve multi-layered tasks.

FLENDER COUPLINGS CATALOG **FLE 10.2** EDITION 2020 EN

flender.com

Further information on the subject of couplings:

flender.com/couplings

Further information on the subject of applications:

flender.com/application-specific-gear-unit

For further information on gears:

flender.com/gearunits

Further information on the subject of service:

flender.com/services

Flender GmbH

Alfred-Flender-Straße 77

46395 Bocholt

Germany

Article no.: FLEX-C10002-00-7600

The information given in this product catalog includes descriptions and performance features that in specific applications do not always apply in the form described or may change through further-development of the products. The desired performance features are binding only if they are expressly agreed on conclusion of contract. Subject to availability for delivery and to technical changes.

flender.com