

dDrive series
by Rossi

Rossi



Decentralized inverter



Contents

1	Rossi for You	6
	1.1 Global presence, local service	8
2	Product Overview	10
	2.1 Features & Benefits	12
	2.2 Introduction	14
	2.3 Benefits	15
	2.4 General specifications	16
	2.5 Operational features	17
	2.6 Operational context	19
	2.7 Electric motors	20
3	Symbols and units of measure	22
	3.1 Symbols and units of measure	24
	3.2 Icons	25
4	Designation	26
	4.1 dDrive inverter selection criterion	28
	4.2 Braking resistance selection (on demand)	29
	4.3 Designation	30
	4.4 dDrive inverter configuration	32
	4.5 Description of dDrive options	34
	4.6 Accessories	35
	4.7 Designation examples	36
	4.8 dDrive name plate data	38
5	Technical specifications	40
	5.1 Technical data	42
	5.2 Wiring diagram	43
	5.3 I/O module data sheet	44
	5.4 Dimensional data	44
	5.5 Compatibility with inverter non-standard designs and accessories	46
	5.6 Inverter power losses (according to EN 61800-9-2)	47
	5.7 Standards and regulations	48
6	Sales Support & Customer Care	42

Rossi for You



Innovation

Rossi S.p.A. offers a wide range of solutions for an ever-changing industrial world, flexible and innovative gearboxes and gearmotors even for custom applications, aimed at maximizing performance and minimizing total cost of ownership (TCO).



High quality, 3 years warranty

Our drive is to innovate and boost operations by manufacturing performing, precise, reliable and high-quality products all over the world. We are always one step forward in offering and developing solutions that can satisfy an unlimited number of application needs, even in the most demanding conditions.



Reliability

We are a reliable company with the right flexibility and know-how to respond to worldwide market requests, in all application fields, without leaving aside our commitment for the environment and value on human safety, to protect everyone's future.



Tools and processes

We continue to invest in new tools and processes, so our highly skilled specialist team in different fields are supporting you to find the best solution suitable for your demands, always by your side on every step of the project.



After-sale service

Highly trained mechanics and support teams can ensure a fast and efficient after-sale service providing support worldwide.



Digital support

In addition to our 24/7 Rossi for You portal, a suite of digital tools provides real-time access to order tracking, invoices, downloading parts drawings, and contacting our service department.

70
YEARS

Experience

Shaped by 70 years of history, Rossi S.p.A. can meet any of your needs, whether it is a standard project or a customized solution.



Global presence local service



Local support

Sales, customer service,
technical support, spare parts



15 branches*



International distribution network*

A global network of subsidiaries and dealers.
From the design phase to after-sales service Rossi S.p.A.
is always by your side, a reliable and flexible local partner.

Rossi for You, the digital suite available 24/7 for
continuous, up-to-date ordering, shipping and service
consultation.

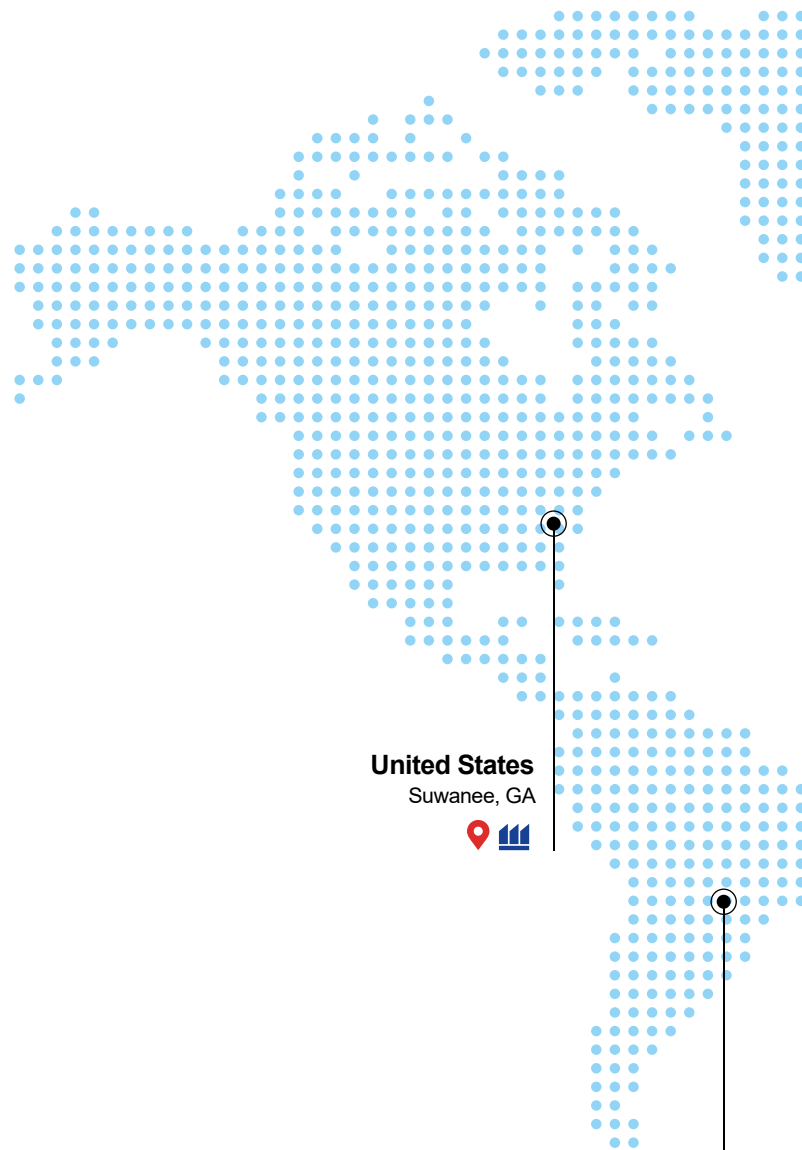

United States
Suwanee, GA



Brazil
Cordeiropolis, SP



*Contacts available at www.rossi.com



Headquarters



Branches



Production facilities/Assembly plants

United Kingdom

Coventry



Netherlands

Panningen



Germany

Dreieich



Poland

Wroclaw



Turkey

Izmir



China

Shanghai



Suzhou



Taiwan

Kaohsiung City



Spain

Barcelona



France

Saint Priest



Italy

Modena



Ganaceto



Lecce



India

Coimbatore



Australia

Perth



South Africa

La Mercy



Malaysia

Kuala Lumpur



Product Overview

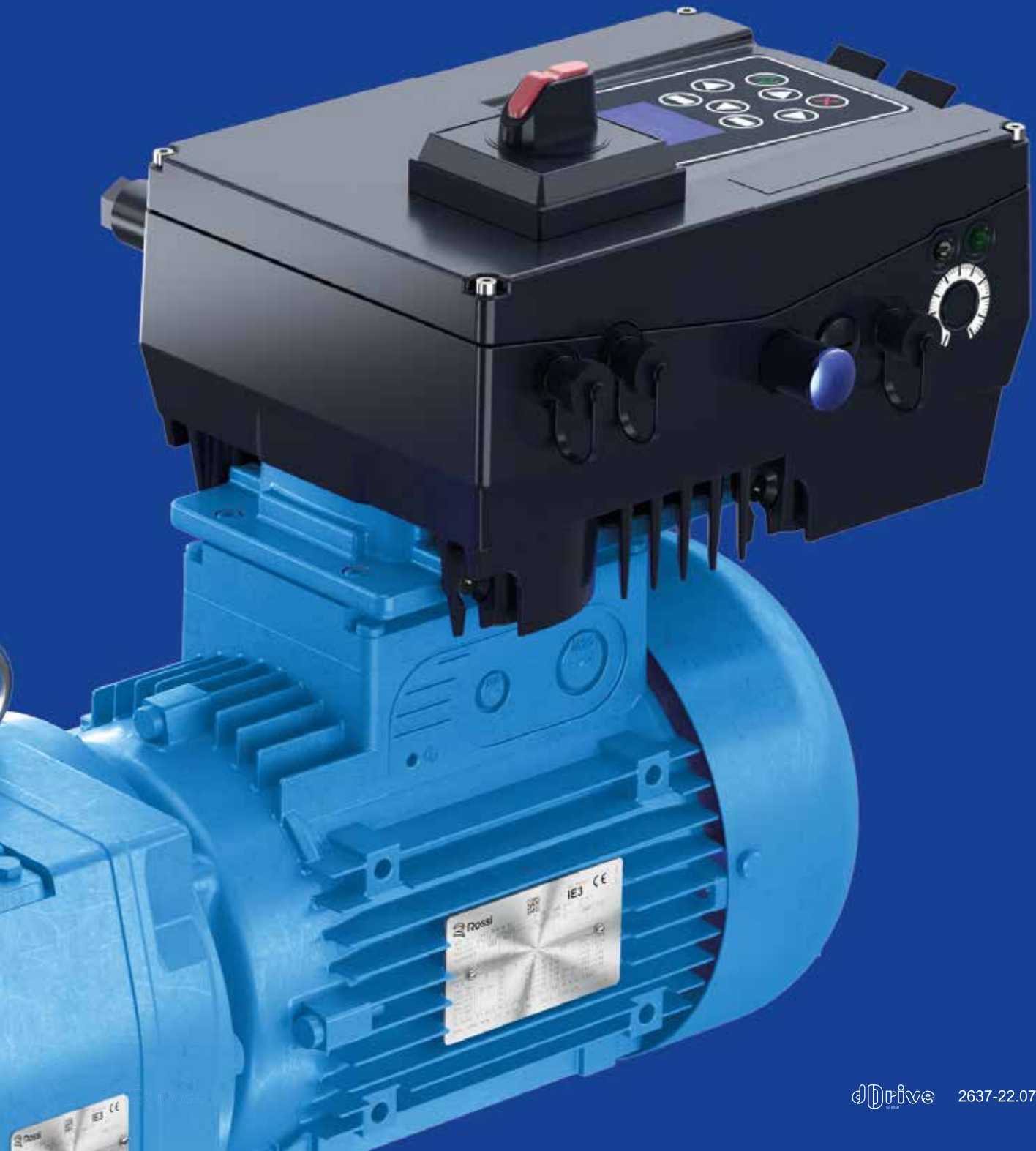

Section contents

2.1	Features & Benefits	12
2.2	Introduction	14
2.3	Benefits	15
2.4	General specifications	16
2.5	Operational features	17
2.5.1	Sensorless Vector Control	17
2.5.2	Field buses	17
2.5.3	Security Functions	18
2.5.4	Programming software and Soft PLC18	18
2.6	Application context	19
2.7	Electric motors	20

2.1

Features & Benefits





Decentralized inverter

Compactness and energy efficiency



100% Made in EU

Superior quality, minimal maintenance



Integrated PLC

Customization of control functions



IP 65 aluminum case

Suitable for harsh environmental conditions



IE3 electric motors

Inverters designed specifically for IE2, IE3 motors



Sensorless Vector Control

Speed vector control without the need for encoders



Safe Torque Off (STO)

High level of security (up to PL E)



Bluetooth Interface

Fast and smart inverter parametrization access

Additional benefits



- High Customer Value
- Short delivery time for standard products
- 3 year warranty

2.2

Introduction

dDrive by Rossi, is the new line of decentralized inverters for asynchronous motor control presented by Rossi. Designed to be installed directly on Rossi's high-efficiency motors in conjunction with a wide selection of gearboxes for industrial applications, **dDrive by Rossi** has a compact and robust design with a high protection IP to hard environmental conditions.

Thanks to an adaptable mechanical interface, the inverter can be mounted nearby the machine or in a wall mounting solution, making the inverter available for any type of installation.

With an in-house assembly, wiring and testing process, Rossi's decentralized inverter reduces application design and installation time.

An innovative modularity concept extends the product's ability to be used in multiple application contexts.



2.2.1 dDrive by Rossi compatible gearmotors range

A Series

Worm
40 ÷ 8020 N m



AS Series

Standardfit Worm
36 ÷ 670 N m



E Series

Helical inline
37 ÷ 10000 N m



iFIT Series

Helical inline New range
145 ÷ 3350 [N m]



iFIT Series

Bevel helical new range
250 ÷ 3650 [N m]



G Series

Helical and bevel helical
85 to 103000 N m



EP Series

Planetary
1600 ÷ 3000000 N m



Due to the dedicated on-board mounting design of Rossi motors and gearmotors, there are multiple benefits over centralized solutions with cabinet-mounted inverters:

- "Plug and play" system with ease of installation and use.
- Reduced electric cabinet size and wiring for motors due to aluminum case and high protection class (IP65).
- Elimination of additional EMI filters in the control cabinet as they are integrated into the inverter resulting in simplified electrical design of the application.
- Immediate remote access to the inverter through Bluetooth interface.
- High inverter overload capacity, 200% for 3s and 150% for 60s, for handling processes where high starting torques and dynamic ramps are required.

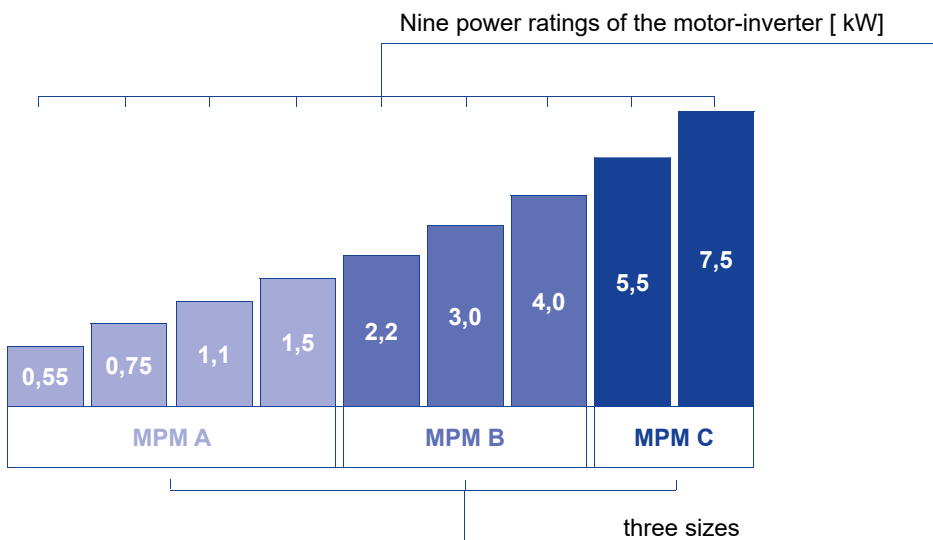

2.4

General specifications

The inverter is available in 3 different housings and 9 inverter sizes based on the nominal power. Designed to withstand mechanical vibrations and thermal stress, the die-cast aluminum housing makes this type of inverter highly robust and suitable for installations in "heavy duty" environments.

All the inverter connections can be done by standard connectors, both power and signals connections. This means a simple and quick inverter installation, with at the meantime a high protection level to dusts and liquids (IP 65).

Available for the motor mounting version, if the application has some constraints (i.e., for space constraints), the inverter can be easily installed close to the motor on the machine in a wall mounting version, just by using a standard electromechanical interface.

When necessary, a convenient main switch can be used to quickly disconnect the device from the power supply without the need to turn off the entire line/application.

The two status LEDs and passive cooling on all sizes of the inverter complete the design of this innovative product.



motor mounting



wall mounting



dDrive PROTECTION/PAINT

- IP 65 aluminum housing
- Painting RAL9005 standard
- Inverter ambient temperature range - 40° C ÷ +50° C

dDrive by Rossi is available in three-phase versions with power ratings from 0.55 kW to 7.5 kW.

The supply voltage range is very wide to adapt to any power grid.

Three-phase voltage: 230V AC and 400V AC 50Hz.

The inverter in motor-board version can be combined with the motor with star or delta connection depending on the characteristics of the application.

During assembly, the inverter is programmed with the motor nameplate values corresponding to the connection made.

Preparing the inverter for a 24 V DC auxiliary voltage ensures that the inverter control electronics can be kept active even in the absence of the power supply.

2.5

Operational features

2.5.1 Sensorless Vector Control

By implementing sensorless vector control, **dDrive by Rossi** guarantees high performance not only for speed control but also for torque control. That means a motor optimization along the whole motor speed range for both sides, performance and energy efficiency with the motor current absorption minimization.

Since this is a sensorless vector control, there is no need for an on-board motor encoder. This benefit, in addition to savings on the components to be installed, allows for simplification of application development.

When there is a heavy load inertia to be handled during the acceleration ramp, **dDrive by Rossi** can provide up to 200% of the rated current for 3s and up to 150% for 60s.

In many circumstances, oversizing of the inverter to control such handling dynamics can thus be avoided.



2.5.2 Field buses

dDrive by Rossi is Modbus RTU field bus based. The connection is available on the same serial connector used for the inverter parametrization. In automation contexts is often required the inverter capability to be connected with several field buses.

dDrive by Rossi extends the possibility of integration with other field buses through the selection of six additional communication protocols among the most widely used in industry.

Depending on the field bus selected, the inverter housing will be equipped with dedicated M12 connectors.



2.5.3 Security Functions

The inverter is equipped with the Safe Torque Off (STO) function in accordance with SIL2 (EN IEC 62061) / PLd (EN ISO 13849-1) standards.

The function is managed through two dedicated safety inputs that can be connected externally via an 8-pin M12 connector. This functionality is available on all sizes of the inverter.

2.5.4 Programming software and SoftPLC

With the inverter programming software, which can be downloaded free of charge from the Rossi website, it is possible to easily access the device parameters and obtain a customized configuration.

Testing and diagnostic operations can also be carried out.

Specifically, through the intuitive graphical navigation interface, the user can: read or write configuration parameters, read and reset any inverter status errors, make measurements on electrical quantities of interest through the use of a four-channel digital oscilloscope, and save these measurements in various formats.

For connection from a PC, the programming cable available as an accessory must be used.

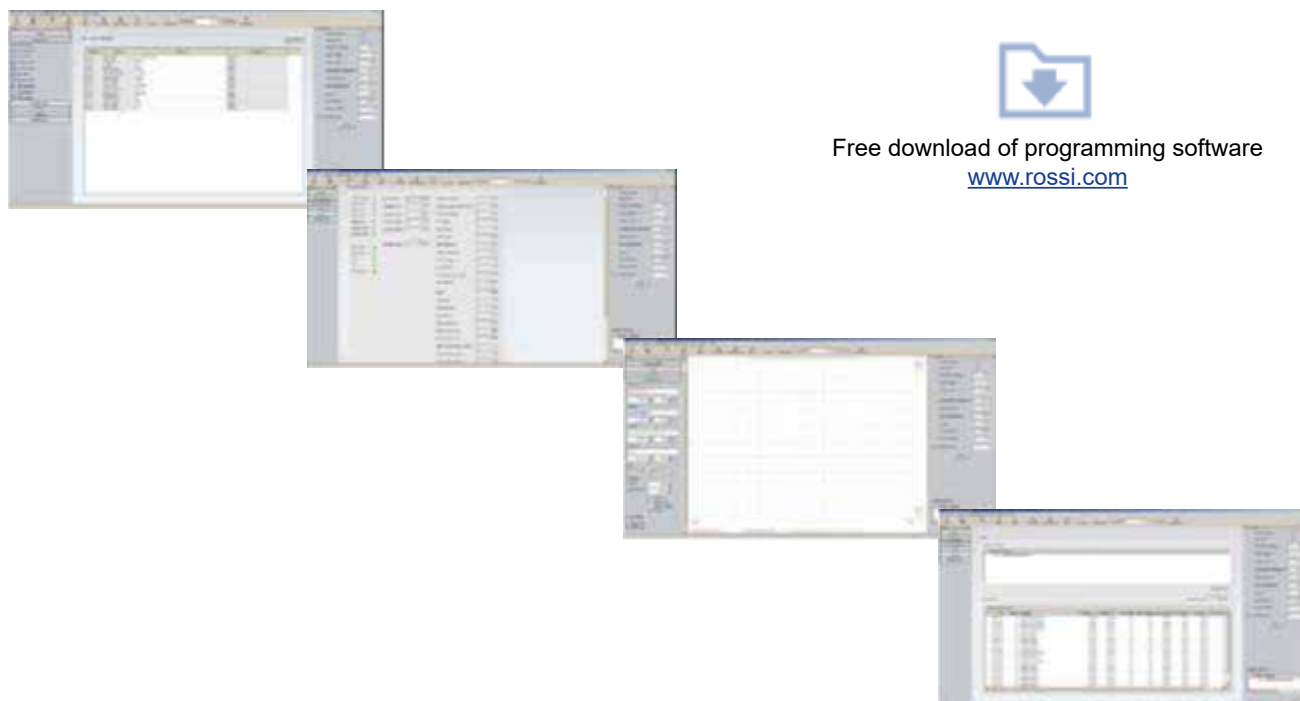

The inverter also has a built-in softPLC whose functions can be exploited through dedicated software (IEC 61131-3). Thus, it is possible to extend the functionality of the inverter in a customized way.

Programming can be developed in the following modes

- FBD (Function Block Diagram),
- ST (Structured Text),
- IL (Instruction List),
- LD (Ladder Diagram)
- SFC (Sequential Function Chart).

The software is available free of charge by request to Rossi Technical Office.

Application context

Thanks to its flexibility of installation, dDrive by Rossi is the right solution for belt conveyors, mixers, pumps and ventilators. By using the same inverter platform and just by selecting the right electromechanical interface, the inverter can be easily installed on the motor or close to it.



Food & Beverage

- Conveyor belts
- Rollers
- Pumps



Transport, Utilities & Handling

- Conveyor belts
- Rollers
- Palletizers



Waste and Water Treatments

- Pumps
- Fans
- Mixers

Reliable electronic components are the active core of this compact and innovative inverter.

High performance level and programming capacity make **dDrive by Rossi** an inverter that can be installed in all of those application contexts where a precision speed level control is mandatory for the right implementation of the application.



dDrive by Rossi is IoT-Capable and ready for Industry 4.0.
Creates the basis for standardized transmission of diagnostic data.

2.7

Electric motors

Rossi TX series electrical motors guarantee high energy efficiency, excellent reliability, low level of maintenance, and are couplable to a wide range of Rossi gearboxes.

Belonging to this family, the HB, HBZ and iFit series are developed for use with the inverter **dDrive by Rossi**.

All of Rossi motors are assembled with high quality components to provide a high level of performance in compliant with the most recent standard energy efficiency regulations to IEC 60034-30.

- Standard and brake motors
- IE3 class of the international efficiency standard (IEC 60034-30) ≥ 0.75 kW
- IE2 Class of the international efficiency standard (IEC 60034-30) ≤ 0.55 kW
- Aluminum frame sizes 63 ... 132
- Cable entry possible from two sides (one each 180°)
- Motor insulation class F, rise temperature B



COMPLIANCE

- Test documents
-  US motors certified to UL
- Machinery Directive 2006/42/EC
- Directive 2011/65/EC RoHS
- Directive «ErP» 2009/125/EC

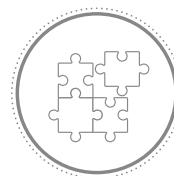

OPTIONAL

- Motor insulation class H
- Bi-metal type and thermistor type (PTC)
- Anti-condensation heater
- Forced fan cooling (IC 416)
- Drip-proof cover
- Double shaft extension
- Incremental encoder sin/cos
- Brake: manual release lever with different orientation, separate brake supply
- Additional executions available upon request



PROTECTION/PAINTING

- Blue paint RAL 5010 corrosivity class C3 (hard, smooth clinging paint)
- For the motor, IP 55 standard and up to IP 66 on request

page intentionally left blank

Symbols and units of measure

Section contents



3.1	Symbols and units of measure	24
3.2	Icons	25

3.1

Symbols and units of measure

Symbols	Description	Units of measure SI
C	downgrading of motor torque	
P_N	motor nominal power	[kW]
I_N	motor nominal current	[A]
f_{min}	minimum motor operating frequency	[Hz]
f_{max}	maximum motor operating frequency	[Hz]
M_N	nominal torque of the motor	[N m]
M	motor torque absorbed by the machine	[N m]
i	transmission ratio	
n_{min}	minimum operating speed required	[min ⁻¹]
$n_{max-operation}$	maximum operating speed required	[min ⁻¹]
n_{max}	motor speed at f_{max} allowed	[min ⁻¹]
n_N	nominal speed of the motor	[min ⁻¹]
R	nominal frequency variation ratio	
P_{max}	maximum braking power required by the application	[kW]
η_e	electrical efficiency	
η_m	mechanical performance (gear reducer, machine, etc.)	
t_i	single braking time	[s]
t_{cycle}	braking cycle time (braking + pause)	[s]
t_{BR}	braking time required by the application	[s]
W_{KIN}	kinetic energy to dissipate	[J]
U_{AUX}	inverter auxiliary voltage	[V]

Icons

Icons	Description	Units of measure SI
	refer to page	
	refer to motor section	
	weight	[kg]

4

Designation

Section contents

4.1	dDrive inverter selection criterion	28
4.1.1	Introduction	28
4.1.2	Inverter and motor size selection	28
4.1.3	Considerations, directions and verifications	28
4.2	Braking resistance selection (on demand)	29
4.3	Designation	30
4.3.1	Motor designation	30
4.3.2	dDrive designation	31
4.4	dDrive inverter configuration	32
4.4.1	Case configuration	32
4.4.2	Lid variant	32
4.4.3	Brake module	33
4.4.4	I/O Module (Input/Output)	33
4.5	Description of dDrive options	34
4.5	Accessories	35
4.7	Designation examples	36
4.7.1	Example 1 : motor-inverter with standard three-phase motor	36
4.7.2	Example 2 : motor-inverter with three-phase brake motor	37
4.8	dDrive inverter nameplate data	38

4.1

dDrive inverter selection criterion

4.1.1 Introduction

For motor operations with frequencies < 25 Hz, please evaluate a motor with forced air cooling fans (depending on operational duty-cycle and environmental temperatures), in order to avoid a motor as well as an inverter oversizing.

Finally, please evaluate the variation ratio between maximum and minimum operational frequency, f_{max} and f_{min} , to determinate the motor connection (star/triangle) and the related inverter size [tables ch.5).

Should the ratio $R = f_{max} / f_{min}$ be in the range of $1 \div 5$, it is advisable to select a star-connected 4-pole motor. For inverter selection, although a size with a rated current equal to that of the motor is sufficient, it is advisable to select an inverter that has a rated current $\geq 1,2 \cdot I_N$, where I_N is the rated current of the 400V star-connected motor.

Should the ratio $R = f_{max} / f_{min}$ be in the range of $5 \div 10$ (maximum motor speed of ≈ 3000 rpm), it is advisable to select a 4-pole delta-connected motor. For inverter selection, it is necessary to select a size that has a rated current $\geq 1,8 \cdot I_N$ where I_N is the rated current of the star-connected motor.

4.1.2 Inverter and motor size selection

For determination of the size of the motor combined with the inverter, refer to chap. 2.9 of TX catalog.

Having determined the motor power, choose the size of the inverter considering a rated current in the range $(1 \div 1,2) \cdot I_N$ motor and with current overload capacity greater than 1,2 times the required torque overload. Normally, for $M_{max}/M_N = 1,5$ you need $I_{max}/I_N \approx 1,7 \div 2$.

4.1.3 Considerations, directions and verifications

Beside the above criteria reported, it's important to consider that, a chopper frequency of the inverter higher than the factory setting (4 kHz), can reduce the motor electrical noise. On the other side, an extra heating can be noticed on both, inverter and motor devices (≈ 10 °C).

If it is necessary to use the inverter at 8 kHz or 16 kHz values, check the correct sizing of the motor-inverter, keeping in mind the indicated temperature rise.

In case of an electrical motor with forced cooling fan, the supply voltage of the fan is directly connected to the grid.

In case of a brake motor, the only Rossi motor series selectable is the HBZ. In this case the motor will be equipped with a DC brake and a Vdc voltage equal to 178 V.

If it is necessary to use the motor-inverter in lifting applications, it is best to contact our engineering department for further verification of size selection and related characteristics of the inverter.

Braking resistance selection (on demand)

Resistance protection rating: IP 20

External braking resistor for regenerative operation with high inertia and/or for short deceleration times. Suitable resistance values for common applications are shown in the table.



For heavier duty, check the continuous braking power P_f required through:

$$P_{max} = 0,5 \cdot W_{KIN} / t_{BR} \text{ [kW]}$$

$$P_f \geq 0,5 \cdot (P_{max} \cdot \eta_e \cdot \eta_m \cdot t_f / t_{cycle}) \text{ [kW]}$$

where:

- P_{max} is the maximum braking power required by the application;
- P_f is the continuous braking power required by the application;
- η_e is the electrical efficiency (inverter + motor). Guide values: 0,54 (0,25 kW) ÷ 0,85 (11 kW);
- η_m is mechanical efficiency (gearbox, machine, etc.);
- t_f single braking time;
- t_{cycle} braking cycle time (braking + pause);
- W_{KIN} kinetic energy to be dissipated;
- t_{BR} braking time required by the application;

	Resistance designation	Description	Inverter power	ED ⁽¹⁾	Layout
			[W]	[%]	
Models	RSI RA	Size A Pf =100W, 100Ω, IP 65, 510 mm cable length, L=110 mm, W=80 mm, H=15 mm	550	16,00	
			750	10,00	
			1100	6,80	
			1500	5,00	
	RSI RB	Size B Pf =200W, 50Ω, IP 65, 510 mm cable length, L=216 mm, W=80 mm, H=15 mm	2200	9,00	
			3000	6,66	
			4000	5,00	
	RSI RC	Size C Pf =240W or 400W[2], 72Ω, IP 65, cable length 510 mm, L=216 mm, W=80 mm, H=30 mm	5500	4,3/7,3 ⁽²⁾	
			7500	3,2/5,3 ⁽²⁾	

⁽¹⁾ Duty cycle calculated over a duration of 120s

⁽²⁾ Without UL

4.3

Designation

4.3.1 Motor designation

HB	3	Z	90S	-	4	230.400	50	-	B5	-	P2
----	---	---	-----	---	---	---------	----	---	----	---	----

Series	Class energy	Brake Integrated	Motor size	N. poles	Voltage power supply	Frequency power supply	Motor mounting position		Non-standard design
							IEC	compact	
HB	2 efficiency IE2	-	63A	2	230.400	50	B5	B12B	-
		Z	63B	4	400	60	B14	...	P2
	3 efficiency IE3		71B	6	...			B30C	AX
		

Refer to the TX motor catalog.

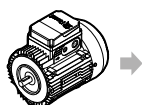

4.3.2 dDrive designation

MPM A	IV01	PW03	LP01	AP00	GH02	DK01	OA00	IO01	CO20	WM
-------	------	------	------	------	------	------	------	------	------	----

Frame size inverter	Power supply voltage	Nominal power	Braking chopper	I/O module chopper	Housing configuration	Lid variant	Brake module	I/O module	Version	Assembly
MPM A	IV01 400V 3-ph	PW03 0.55 kW	LP01 without braking chopper	AP00 I/O slots	GH02	DK01	OA00	IO01	CO20 material	- on board motor WM wall
MPM B		PW04 0.75 kW			LP02 with braking chopper	GH45	DK02	OA10		
MPM C		PW05 1.10 kW	GH51			DK05	OA13	IO13		
		PW06 1.50 kW	GH55		DK05	OA30	IO23			
		PW07 2.20 kW	GH01		DK11		IO33			
		PW08 3.00 kW	GH44		DK12		IO02			
		PW09 4.00 kW	GH50				IO04			
		PW10 5.50 kW	GH54		DK15		IO14			
		PW11 7.50 kW						IO24		
								IO34		

page 30

page 30

page 31

page 31

4.4

dDrive inverter configuration

4.4.1 Housing configuration

Variants of the "housing configuration" field define the inverter characteristics relevant to the presence of components such as potentiometer, harting connectors, cable glands, and cooling system.

Option LP01			
Housing	Designation		Description
	Without potentiometer	With potentiometer	
	GH02	GH01	Passive Cooling
	GH51	GH50	Passive Cooling + Harting connector

Option LP02			
Housing	Designation		Description
	Without potentiometer	With potentiometer	
	GH45	GH44	Passive Cooling + Braking Chopper
	GH55	GH54	Passive Cooling + Harting Connectors + Braking Chopper

4.4.2 Lid variant

Variants of the "lid configuration" field identify the presence or absence of inverter control/management elements on the lid such as: integrated keypad, MMI, and power disconnect switch.

Lid	Designation		Description
	Without main switch	With main switch	
	DK01 ⁽¹⁾	DK11	Material
	DK02 ⁽²⁾	DK12	With integrated keyboard
DK05 ⁽³⁾	DK15	With integrated MMI	

The respective variants DK11, DK12 and DK15 correspond to the equivalent DK01, DK02 and DH05, with the choice of the power disconnecter integrated on the inverter cover.

¹⁾ Where it is not necessary to have the power disconnecter integrated on the cover, select DH01 for a configuration of the standard enclosure and devoid of additional adjustment elements.

²⁾ Select option DK02 if required to have an integrated membrane keypad on the inverter cover.

³⁾ Select option DK05 if required to have an integrated keyboard with MMI display.

4.4.3 Brake module

Variants of the "brake module" field define the presence or absence of the brake module on board the inverter to manage the motor brake.

	Designation	HB	HBZ	Description
Brake	OA00	•	-	Without brake module
	OA10	•	-	Without brake module + main switch
	OA13	-	•	With brake module + main switch
	OA30	-	•	Brake module only

4.4.4 I/O Module (Input/Output)

	Designation	Variant	Description
Input/Output Module	IO01	3DI/1DO/1AI	3 digital inputs (DI), 1 digital output (DO), 1 analog input (AI)
	IO03	3DI/1DO/1AI/M12	3 digital inputs (DI), 1 digital output (DO), 1 analog input (AI), 1 M12 connector for MMI
	IO13	3DI/1DO/1AI/M12/STO	3 digital inputs (DI), 1 digital output (DO), 1 analog input (AI), 1 M12 connector for MMI, 1 STO input
	IO23	3DI/1DO/1AI/M12/FB	3 digital inputs (DI), 1 digital output (DO), 1 analog input (AI), 1 M12 connector for MMI, 1 fieldbus module (FB)
	IO33	3DI/1DO/1AI/M12/FB/STO	3 digital inputs (DI), 1 digital output (DO), 1 analog input (AI), 1 M12 connector for MMI, 1 fieldbus module (FB), 1 STO input

Specifically, select option IO01 if safety options (STO) and fieldbus (FB) are not needed in the configuration with inverter enclosure without keypad or integrated MMI.

Select option IO03 if the inverter configuration includes either the keypad or the integrated MMI keypad and, as with option IO01, the safety (STO) and fieldbus (FB) options are not required.

Option IO23 adds to the previous one (IO03) the presence of a fieldbus module among the available ones (ProfiNet/EtherCat/EthernetIP/CanOpen).

While the IO13 option integrates the safety STO input. The last selectable option IO33, includes all the previous ones indicated.



Options IO02, IO04, IO14, IO24 and IO34, mirror the options described above, but with the addition of the built-in Bluetooth interface.

4.5

Description of dDrive options

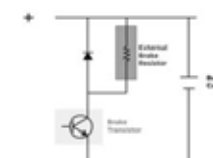
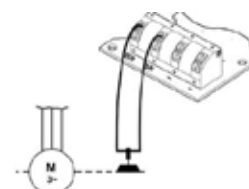
		Designation	Description
Options	Main switch	..DK11..OA10 ..DK12..OA10 ..DK15..OA10 ..DK11..OA13 ..DK12..OA13 ..DK15..OA13	Main switch that can be integrated on the cover of the inverter for supply voltage separation in an omnipolar manner.
	Harting Connectors	..GH50. ..GH51. ..GH54. ..GH55.	Industrial Harting connectors (IP68) for quick connection to power supply. Possible implementation of a through connection (Daisy Chain).
	Brake module	..OA30. ..OA13.	Rectifier module for DC brake control. The rectifier module is supplied with AC voltage and controls the brake with DC voltage.
	Brake chopper	..LP02..GH44 ..LP02..GH45 ..LP02..GH54 ..LP02..GH55	Braking chopper for connecting a braking resistor. Available through the provision of two additional terminals (B+ and B-) to which to connect the braking resistor appropriately sized.
	Foil keypad	..DK02. ..DK12.	Foil keyboard integrated on the cover, consisting of 6 programmable function buttons, 5 LED indicators and a potentiometer for motor speed adjustment.
	Integrated MMI	..DK05. ..DK15.	Programmable MMI keypad with display integrated on lid. Made of eight programmable buttons for Start, Stop, Reset alarms, Reverse speed mode. Liquid crystal display for reading/writing parameters.

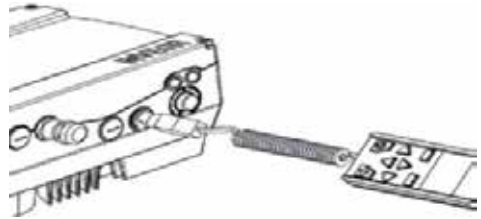

		Designation	Description
Accessories	Portable MMI interface	RSI MMI	<p>Thanks to the MMI is possible to make inverter commissioning, modifying or downloading inverter parametrization or inverter diagnostics. The parameters can be downloaded from the inverter to MMI and vice versa. Up to 8 inverter parameters dataset can be saved. The MMI is available with 3 meters cable, RJ9/M12 connector.</p> 
	Programming cable	RSI CBL PC	<p>To make the connection through the laptop programming software is needed to use the appropriate communication cable available as accessory. Communication cable of 2-meter length with USB connector on one side and M12 connector on the other side and built-in 485 converter.</p> 
	Interface Bluetooth	RSI BLTH	<p>With the help of the Bluetooth interface and a mobile device, you are able to put the dDrive inverter into operation. To establish communication, simply download the free mobile application from Google Play Store (ANDROID) or App Store (Apple IOS) directly to your mobile device.</p> 

4.7

Designation examples

4.7.1 Example 1: motor-inverter with standard three-phase motor

Motor

HB	3	-	90S	4	230/400	50	B5	-
----	---	---	-----	---	---------	----	----	---

- HB-motor,
- IE3 efficiency (3)
- Motor size 90S
- Number of poles 4
- Supply voltage 230-400 V at 50 Hz
- Motor with IEC B5 mounting position
- No special design

dDrive Inverter by Rossi

MPM A	IV01	PW05	LP02	AP00	GH45	DK01	OA00	IO01	CO20	-
-------	------	------	------	------	------	------	------	------	------	---

- Inverter size A (MPM A)
- Inverter three-phase supply voltage 400 V (IV01)
- Nominal power 1,1 kW (PW05)
- Power board with braking chopper for external braking resistance (LP02)
- Control board with I/O module (AP00)
- Housing without potentiometer with predisposition for braking resistor (GH45)
- Standard lid without main switch (DK01)
- No brake rectifier (inverter for motor series HB) (OA00)
- Input/output standard module without integrated Bluetooth interface (IO01)
- Standard software version (CO20)
- Mounting on board motor

4.7.1 Example 2: motor-inverter with three-phase brake motor

Motor

HB	3	Z	100LA	4	230/400	50	B14	F30
----	---	---	-------	---	---------	----	-----	-----

- Brake motor type HB
- IE3 efficiency,
- Motor size 100LA
- Number of poles 4
- Supply voltage 230-400 V at 50 Hz
- Motor with IEC B14 mounting position
- Non-standard design - Brake supply voltage 400V (178 V DC) (F30)

dDrive Inverter by Rossi

MPM B	IV01	PW07	LP01	AP00	GH01	DK11	OA13	IO13	CO20	-
-------	------	------	------	------	------	------	------	------	------	---

- Inverter size B (MPM B)
- Inverter three-phase supply voltage 400 V (IV01)
- Nominal power 2.2 kW (PW07)
- Power board without braking chopper (LP01)
- Control board with I/O module (AP00)
- Housing with potentiometer and predisposition for external braking resistance (GH01)
- Lid with main switch (DK11)
- Inverter brake rectifier for HBZ motor (OA13)
- Input/Output module with STO and without Bluetooth interface (IO13)
- Standard software version (CO20)
- Mounting on board motor

4.8

dDrive inverter nameplate data

Each inverter **dDrive by Rossi** is provided with a nameplate containing main information necessary for correct product identification.

The nameplate must not be removed and must remain intact and readable.

Please refer to the TX series motor catalog (Ch.3) for each related motor nameplate.

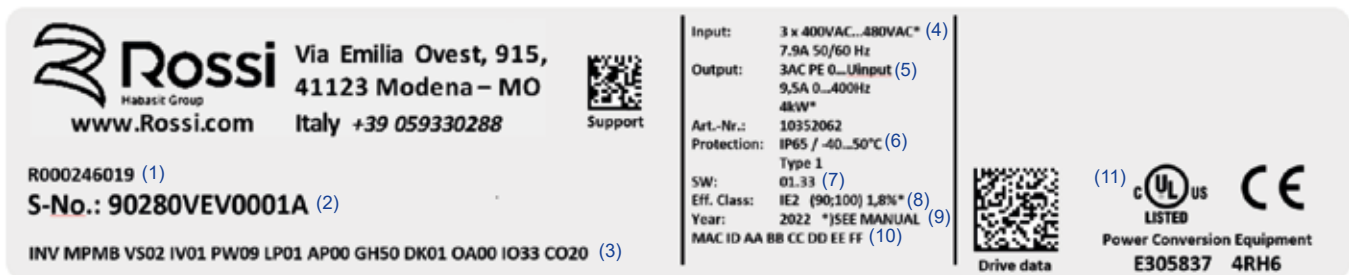
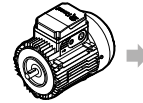

- | | |
|---|---|
| (1) Unique inverter configuration code. | (6) IP protection class and temperature range |
| (2) Inverter serial number | (7) Inverter firmware version |
| (3) Inverter designation | (8) Power losses and energy efficiency |
| (4) Inverter input data | (9) Year of production |
| Supply voltage | (10) MAC address |
| Absorbed current | (11) Certificates and compliance |
| Grid frequency | |
| (5) Inverter output data | |
| Output Voltage | |
| Rated current | |
| Frequency range of output signal | |
| Rated power | |

Any data on the inverter nameplate must be specified in case of a spare part/replacement order.

page intentionally left blank

Technical specifications

Section contents

5.1	Technical Data	42
5.2	Wiring diagram	43
5.3	I/O module data sheet	44
5.4	Dimensional data	44
5.4.1	Inverter + star connected motor 400V 50 Hz	45
5.4.2	Inverter + delta connected motor 400V 87 Hz	32
5.5	Compatibility with motor non-standard designs and accessories	46
5.6	Inverter power losses (according to EN 61800-9-2)	47
5.7	Standards and Regulations	48

5.1

Inverter technical data

		Size of dDrive by Rossi								
		MPM A			MPM B			MPM C		
Electrical data	Recommended motor power [kW]	0,55	0,75	1,1	1,5	2,2	3	4	5,5	7,5
	Line voltage [V]	3 x 200 V AC -10 % to 480 V AC +10 %. 280 V DC -10 % TO 680 V DC +10 % ¹⁾								
	Grid frequency [Hz]	50/60 Hz ± 6%								
	Electrical systems	TN / TT								
	Input current (@400V) [A]	1,4	1,9	2,6	3,3	4,6	6,2	7,9	10,8	13,8
	Rated output current (@400V) [A]	1,7	2,3	3,1	4	5,6	7,5	9,5	13	16,5
	Minimum braking chopper resistance [Ω]	100				50				
	60 s overload [%]	150								
	3 s overload [%]	200								
	Switching frequency [Hz]	Automatic regardless of temperature 2 kHz, 4 kHz, 6 kHz, 8 kHz, 12 kHz, 16 kHz (initial setting 4 kHz)								
	Output frequency [Hz]	0 Hz ÷ 599 Hz								
DIN EN 61800-5 Contact current [mA]	< 3.5 mA ²⁾									
Functions	Protective functions	Overvoltage and undervoltage, I ² t restriction, short circuit, ground leak, motor and inverter temperature, stall prevention, blocking detection								
	Software functions	Torque control, multi-pumps, fixed frequencies, data record changeover, flying restart, motor current limit								
Mechanical data	Housing	Two-part aluminum die-cast housing								
	Dimensions (LxWxH) [mm]	233 x 153 x 120			270 x 189 x 140			307 x 223 x 181		
	Weight, including adapter plate 	3,9			5,0			8,7		
	Protection class	IP 65								
Environmental conditions	Cooling	Passive cooling								
	Ambient temperature [°C]	-40 °C TO +50 °C (without derating)								
	Altitude of the installation site [m]	Up to 1000 m above sea level. / over 1000 m at reduced performance (1% per 100 m) / over 2000 m see operational manual								
	Relative air humidity [%]	≤ 96 %, no condensation is allowed								
	Vibration risk class (DIN EN 60721-3-3)	3M7 (3g)								
EMC (DIN-EN-61800-3)	C2									

¹⁾ In observance of the overvoltage category.

²⁾ Installed on asynchronous motor 1LA7

Wiring diagram

The number of inputs/outputs as well as the ability to have safety features (STO) can be configured through the choice of different I/O modules.

Example of inverter connection with IO01 module (3DI-1DO-1AI) ¹⁾:

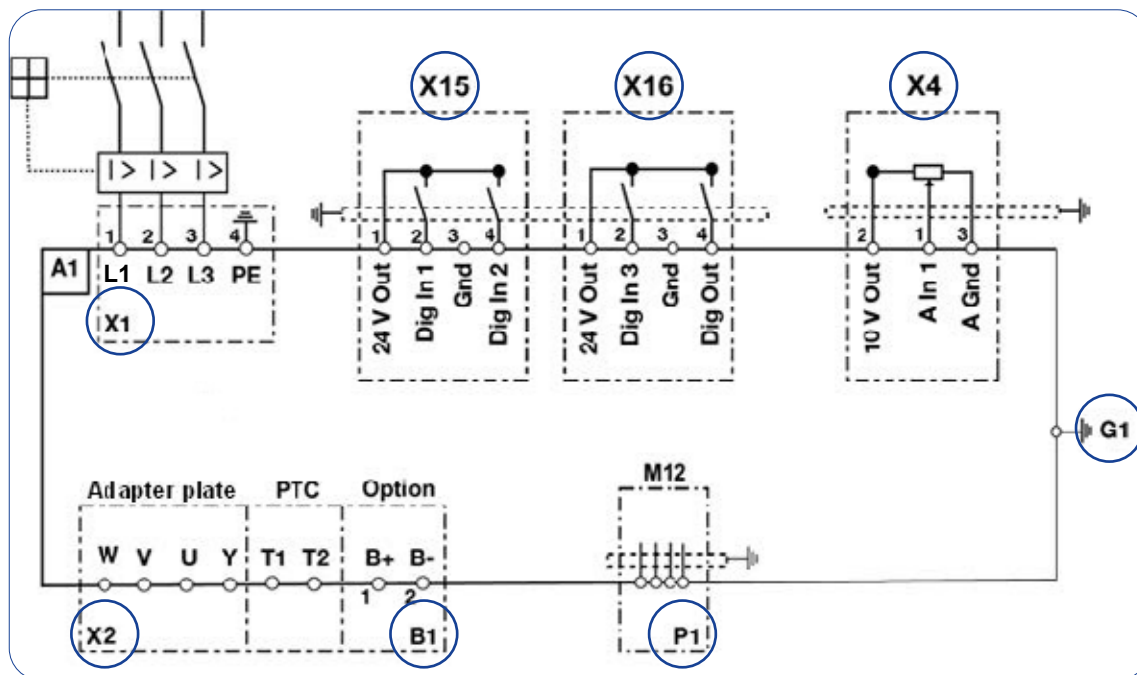

Segment	Description
A1	Inverter model: 3 x 400 V AC
B1	Connection for external braking resistor (optional)
G1	M6 ground screw (connection for residual current > 3.5 mA)
P1	RS485 programming interface
X4	Built-in potentiometer/analog input 1
T1/T2	Motor protection switch
X1	Power terminals
X2	Motor cable terminals
X15-X16	Digital inputs and outputs

¹⁾ For other models of I/O modules refer to the user manual **dDrive by Rossi**

5.3

I/O module data sheet

IO01 module (3DI-1DO-1ALI) ¹⁾

Type	Function
Digital inputs 1-3	Switching level - low < 2 V / high > 18 V
	I_{max} (at 24 V) = 3 mA
	R_{in} = 8.6 k Ω
Analog input 1	Input +/- 10 V
	Input 4 \div 20 mA
	10-bit resolution
	Tolerances +/- 2 %
	Input voltage: R_{in} = 10 k Ω
	Input current: Load resistance = 500 Ω
Digital output 1	I_{max} = 20 mA
Auxiliary Voltage 24 V	Auxiliary voltage U_{AUX} = 24 V DC
	I_{max} = 100 mA
Auxiliary Voltage 10 V	Auxiliary voltage U_{AUX} = 10 V DC
	I_{max} = 30 mA

¹⁾ For other models of I/O modules refer to the user manual **dDrive by Rossi**

5.4

Dimensional data

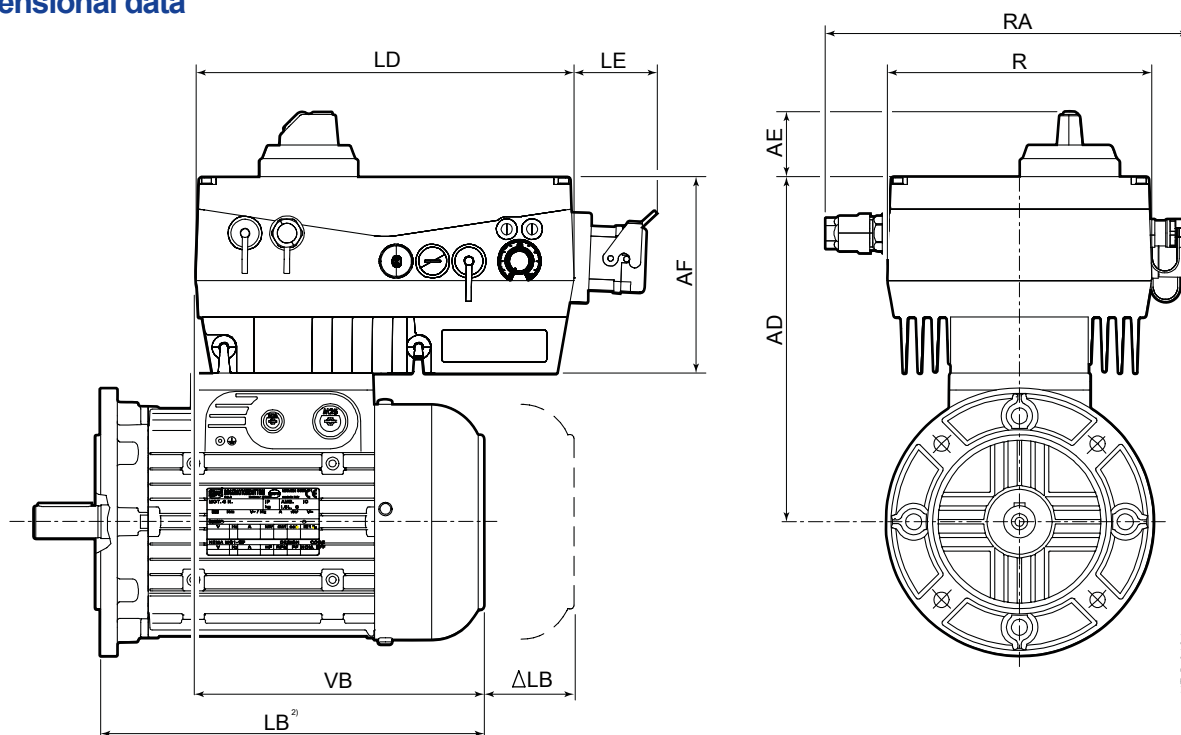

²⁾ Refer to the TX motor catalog. Refer to the TX motor catalog for shaft and flange dimensions.

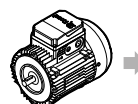

5.4.1 Inverter + star connected motor 400V 50 Hz

dDrive		Motor	Dimensions										
Size	Power [kW]	Size HB-HBZ	LD	THE	RA	R	AF	AE	VB	AD	ΔLB		
											Servo fan	Brake motor	Fan cooled brake motor
											[mm]		
MPM A	0,55	71B 4	233	60	222	153	128	46	163	213	63	62	68
		71C 4											
		80A 4											
	0,75	80B 4									65	69	73
		90S 4											
1,5	90L 4	82	79	88									
MPM B	2,2	100LA 4	270	60	257	189	145	47	215	261	89	95	78
	3	112MA 4									81	99	
	4	112M 4											
MPM C	5,5	132S 4	307	-	309	223	181	45,5	294	343	88	108	81
	7,5	132M 4											

5.4.2 Inverter + motor connected to delta 400V 87 Hz

dDrive		Motor	Dimensions												
Size	Power [kW]	Size HB-HBZ	LD	THE	RA	R	AF	AE	VB	AD	ΔLB				
											Servo fan	Brake motor	Fan cooled brake motor		
											[mm]				
MPM A	0,75	71B 4	233	60	222	153	128	46	163	213	63	62	68		
	1,1	71C 4													
		80A 4									167	220	65	69	73
		80B 4													
MPM B	2,2	90S 4	270	60	257	189	145	47	205	251	82	79	88		
	3	90L 4													
	4	100LA 4							215	261	89	95			
MPM C	5,5	112MA 4	307	-	309	223	181	45,5	224	316	81	99	78		
	7,5	112M 4													

5.5

Compatibility with special executions and motor accessories

Ref.	Description	Option code	Motor series		Inverter compatibility	
			HB	HBZ	motor mounting	wall
(1)	Non-standard motor supply	—	•	•	1)	1)
(2)	Motor shaft axially fastened	,AX	•	-	Compatible	Compatible
(3)	Motor insulation class H	,H	•	•	Compatible	Compatible
(7)	Low temperature design (-30 °C)	,BT	•	•	Compatible	Compatible
(8)	Condensate drain holes	,CD	•	•	Compatible	Compatible
(9)	Additional winding impregnation	,SP	•	•	Compatible	Compatible
(13)	Anti-condensation heater	,S	•	•	Not compatible	Compatible
(14)	Terminal box on one side (IM B3 and derivatives, 90 ...132)	,P	•	•	Compatible	Compatible
(16)	Second shaft end	,AA	•	•	Compatible	Compatible
(17)	Axial independent cooling fan	,V...	•	•	2)	Compatible
(18)	Axial independent cooling fan and encoder	,V...,E...	•	•	1)	1)
(19)	Thermistor type thermal probes (PTC)	,T15	•	•	Compatible	Compatible
(20)	Bi-metal type thermal probes	,B15	•	•	Compatible	Compatible
(21)	Drip-proof cover	,PP	•	•	Compatible	Compatible
(23)	Flywheel	,W	-	•	Compatible	Compatible
(25)	Lever for manual release with automatic return ³⁾	,L...,L3	-	•	Compatible ⁴⁾	Compatible
(26)	Separate brake supply	,F30	-	•	Compatible	Compatible
(35)	Light alloy fan	,VL	•	•	1)	1)
(36)	Encoder	,E1...,E5	•	•	Not compatible	Not compatible
(42)	UL motor certified	,UL	•	•	Not compatible	Compatible
(47)	Design for humid and corrosive environment	,UC	-	•	Compatible	Compatible
	Stainless steel brake disc, bolts and screws	,DB	-	•	Compatible	Compatible
(48)	IP 56 protection	,IP 56	-	•	Compatible	Compatible
(49)	IP 65 protection	,IP 65	-	•	Compatible	Compatible
(53)	Brake with microswitch	,SB,SU	-	•	Not compatible	Compatible
(54)	Brake with ready air-gap reset	,RF	-	•	Compatible	Compatible
(61)	Manual rotation	,MM	-	•	Compatible	Compatible
(62)	Motor pre-arranged for encoder	,PE	•	•	1)	1)
(63)	Axial cooling fan and motor pre-arranged for encoder	,V...,PE...	•	•	Compatible ¹⁾²⁾	Compatible ¹⁾
(64)	IP 66 protection	,IP 66	•	-	Compatible ¹⁾	Compatible ¹⁾

- Not available on motor

- Available on motor

¹⁾ Contact technical department.

²⁾ Solution with axial independent cooling fan connectors.

³⁾ Refer to the TX series motor catalog for the positioning of the release lever with respect to the terminal box.

⁴⁾ Placement not allowed: L (aligned with motor terminal box).



Inverter power losses (according to EN 61800-9-2)

Frequency inverters **dDrive by Rossi** meet the highest energy efficiency requirements.

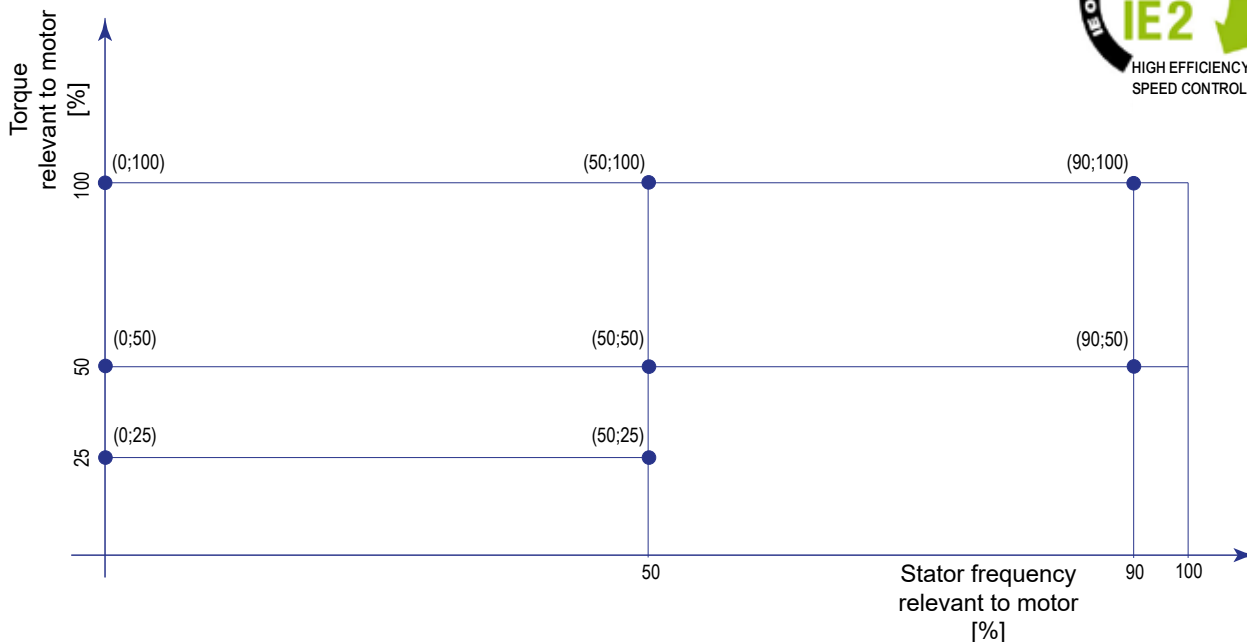

dDrive				Operating conditions - % stator frequency motor								Standby losses	IE class
				Operating conditions - % motor torque									
Size	Power	Supply voltage	Nominal voltage	(90 100)	(50 100)	(10 100)	(90 50)	(50 50)	(10 50)	(50 25)	(10 25)	[W]	
				[kW]	[V]	[A]	Absolute power loss [W] ^{1) 2)}						
				Relative losses [%] ^{1) 2) 3)}									
MPM A	0,55	400	1,7	24	24	27	22	20	25	24	25	5	IE2
				2,3	2,2	2,5	2	1,9	2,4	2,2	2,3		
	0,75	400	2,3	29	28	32	23	21	28	25	27	5	IE2
				2	1,9	2,2	1,6	1,5	2	1,7	1,9		
MPM B	1,1	400	3,1	35	30	38	27	26	31	26	28	5	IE2
				1,8	1,6	2	1,4	1,3	1,6	1,4	1,4		
	1,5	400	4,0	45	39	46	31	27	36	25	31	5	IE2
				1,8	1,6	1,8	1,3	1,1	1,4	1	1,2		
MPM C	2,2	400	5,6	61	60	65	46	38	48	37	42	7	IE2
				1,7	1,7	1,9	1,3	1,1	1,4	1	1,2		
	3	400	7,5	83	62	80	54	38	58	28	51	7	IE2
				1,8	1,3	1,7	1,2	0,8	1,3	0,6	1,1		
MPM C	4	400	9,5	107	80	98	66	51	70	31	58	7	IE2
				1,8	1,4	1,7	1,1	0,9	1,2	0,5	1		
	5,5	400	13,0	149	114	125	69	52	76	44	70	7	IE2
				1,8	1,4	1,5	0,9	0,6	0,9	0,5	0,9		
	7,5	400	16,5	203	157	166	98	75	95	58	78	7	IE2
				2	1,5	1,6	0,9	0,7	0,9	0,6	0,8		

¹⁾ Loss values are calculated at a switching frequency of 4 kHz.
²⁾ Loss values include an addition of 10% in accordance with the standard.
³⁾ Relative losses refer to the device's rated apparent power.

5.7

Standards and Regulations

Frequency inverters **dDrive by Rossi** comply with the systems and safety standards as listed below.

EN 61800 - 5 - 1 (2007)	Adjustable speed electrical power drive systems - Part 5 -1: Safety requirements - Electrical, thermal and energy
EN 61800 - 3 (2004/A1:2012)	Adjustable speed electrical power drive systems. EMC requirements and specific test methods
EN 50581 (2012)	Technical documentation for the assessment of electrical and electronic products with respect to the restriction of hazardous substances
EN 61800 - 5 - 2 (2007)	Adjustable speed electrical power drive systems - Part 5-2: Safety
EN 62061 (2005/A1:2013/AC:2010)	Safety of machinery - Functional safety of safety-related electrical, electronic and programmable electronic control systems
EN ISO 13849 - 1(2008/AC-2009)	Safety of machinery - Safety-related parts of control systems - Part 1: General principles for design (ISO 13849-1:2006)
IEC 61508 - 1 (2010 - 04)	Functional safety of electrical/electronic/programmable electronic safety-related systems - Part 1: General requirements
IEC 61508 - 2 (2010 - 04)	Functional safety of electrical/electronic/programmable electronic safety-related systems - Part 2: Requirements for electrical/electronic/programmable electronic safety-related systems

page intentionally left blank

Sales Support & Customer Care

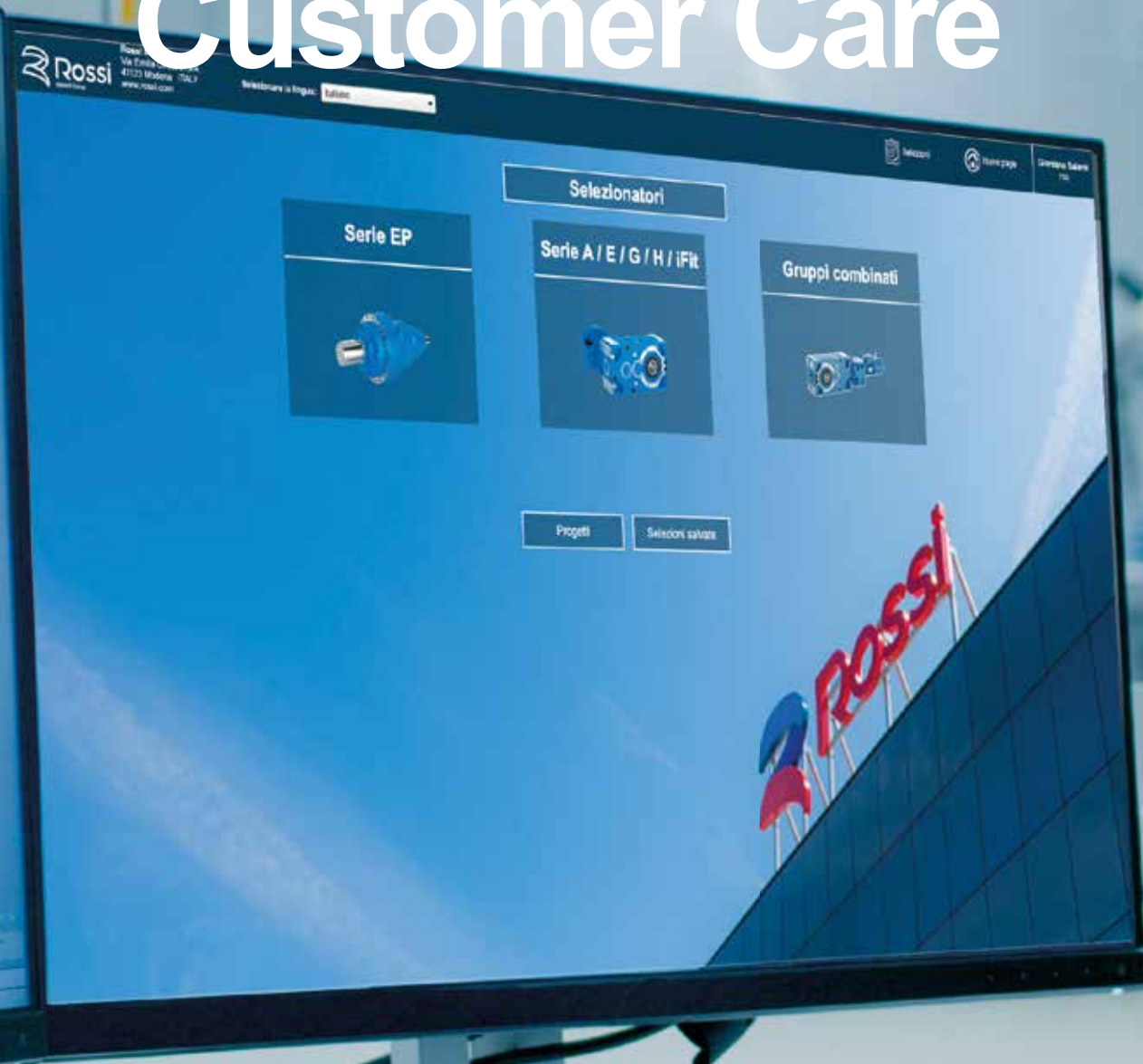

With our online selection tools, you will find the right solution for your machines

Our modular approach doesn't stop at the delivery of a product or solution. For us this is just the start. With strong online support systems, our customers have access to leading interactive product and service care. We aim to deliver performance improvement and on-going assistance during the entire system life-cycle.



Pre-sales

Wherever a request comes from, worldwide, our engineers can quickly follow up the inquiries. A dedicated team with skilled technicians provides application support offering assistance and innovative solutions from orientation to concept development.



After-sales

We can help you maintain your line efficiency, turning costly downtime into profitable uptime. Spare parts, maintenance (including agreements), technical and field support, including help desk assistance. For emergencies, stock replenishment or planned maintenance, we deliver original spare parts wherever you are, in a timely manner.



Training

We organize standard and customized courses on how to safely and efficiently operate, maintain and troubleshoot equipment. Staff needs to understand how to properly use the system and how to take advantage of features to maximize productivity and efficiency.



Digital support

Rossi for You is a suite of digital support tools enabling real-time access to your order tracking, invoices, spare part tables download and contact to our service. Fast and easy online access is available 24/7, in 5 languages.

Notes

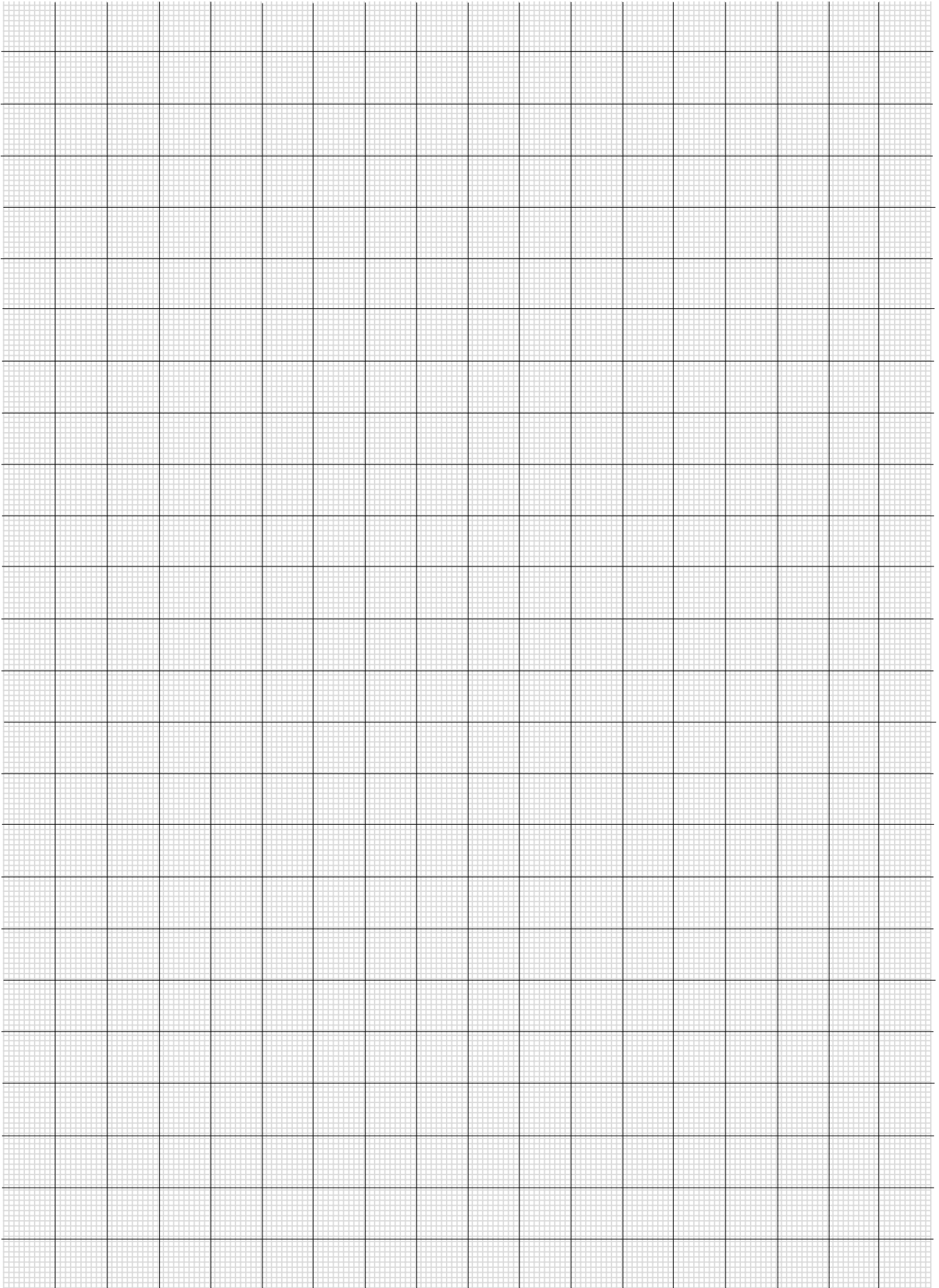

Notes

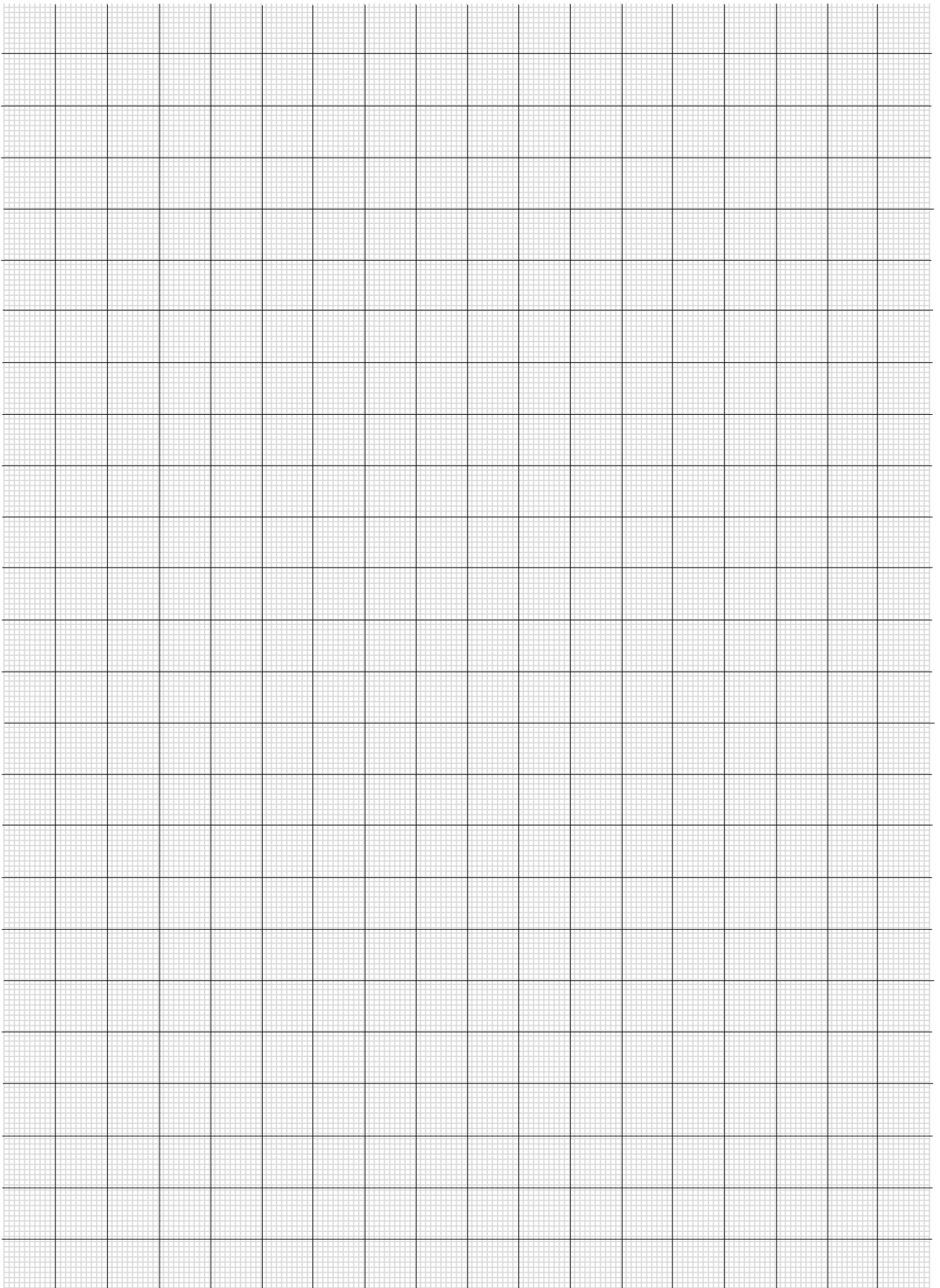

page intentionally left blank

Rossi S.p.A.
Via Emilia Ovest 915/A
41123 Modena - Italy

Phone +39 059 33 02 88

info@rossi.com
www.rossi.com

2637.CAT.dDRIVE-22.07-0-EN

© Rossi S.p.A. Rossi reserves the right to make any modification whenever to this publication contents. The information given in this document only contains general descriptions and/or performance features which may not always specifically reflect those described.

The Customer is responsible for the correct selection and application of product in view of its industrial and/or commercial needs, unless the use has been recommended by technical qualified personnel of Rossi, who were duly informed about Customer's application purposes. In this case all the necessary data required for the selection shall be communicated exactly and in writing by the Customer, stated in the order and confirmed by Rossi. The Customer is always responsible for the safety of product applications. Every care has been taken in the drawing up of the catalog to ensure the accuracy of the information contained in this publication, however Rossi can accept no responsibility for any errors, omissions or outdated data. Due to the constant evolution of the state of the art, Rossi reserves the right to make any modification whenever to this publication contents. The responsibility for the product selection is of the Customer, excluding different agreements duly legalized in writing and undersigned by the Parties.